

# BITO

*Die pfiffige Lösung*

## **Ständerregal Rack fixe Bakkenstelling Bin racking**

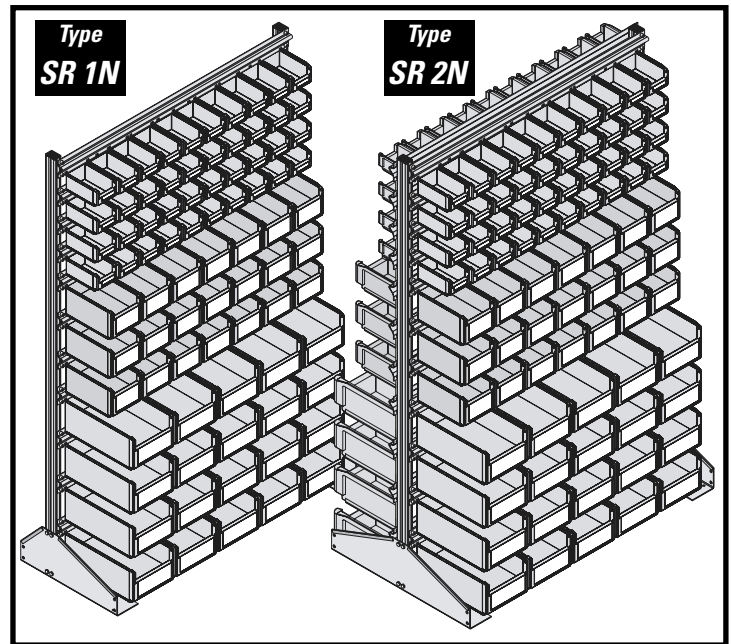

**Aufbau- und Betriebsanleitung  
Instructions de montage et d'utilisation  
Richtlijnen en montagehandleiding  
Instructions for assembly and use**

**SR 1N + SR 2N**

Technische Änderungen vorbehalten. Modifications techniques réservées. Technische wijzigingen voorbehouden. Technical modifications reserved.

**Ständerregal**

Stand  
**10-2004**

**DIN EN ISO 9001**

Inhalt / Sommaire / Inhoud / List of contents

Unbedingt beachten / Réglementations importantes /  
Belangrijke richtlijnen / Important regulations **3**



Sicherheitsvorschriften  
Consignes de sécurité **3**  
Veiligheidsvoorschriften  
Accident prevention regulations



Belastungshinweise  
Capacité de charge **3**  
Draagvermogen  
Load capacity

Übersicht / Aperçu / Overzicht / Survey **4-5**

Montage / Assembly **6-10**



C-Profil  
Profils en C **6**  
C-profielen  
C-sections



Querträger  
Piètement **7**  
Voetplaat  
Foot plate



Aufhängeschiene  
Rail d'accrochage **8**  
Ophangrail  
Bin acceptor rail



Einteilung der Aufhängeschiene  
Positionnement des rails d'accrochage **9**  
Positionering van de ophangrails  
Location of bin acceptor rails



Stopfen/Klemmschiene  
Embout/Rail protecteur **10**  
Afsluitkapje/Beschermingsrail  
End cap/Protection rail

Belastungen / Capacité de charge /  
Draagvermogen / Load capacity **11**

Sicherheitsvorschriften / Consignes de sécurité /  
Veiligheidsvoorschriften / Accident prevention regulations



**BGR 234** (ZH 1/428)

Richtlinien für Lagereinrichtungen und -geräte der  
Berufsgenossenschaften.

En tant que responsable de l'exploitation, veuillez respecter  
les réglementations de sécurité en vigueur.

Gebruikers dienen rekening te houden met de geldende  
nationale veiligheidsvoorschriften inzake magazijninrichtingen.

Users of the installation have to observe the relevant health  
and safety regulations.

Belastungshinweise / Capacité de charge /  
Draagvermogen / Load capacity

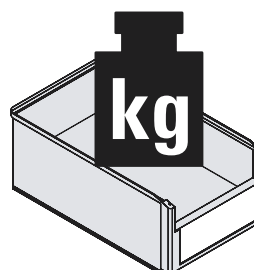
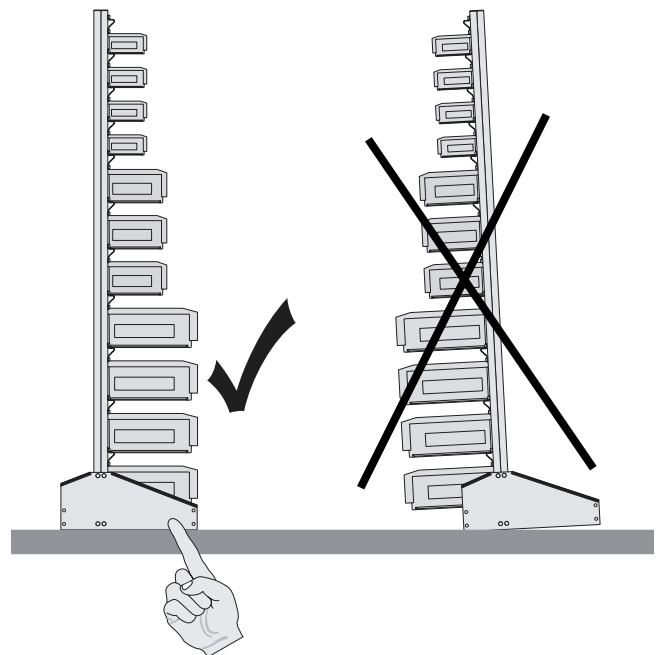

Seite  
Page **11**  
Pagina  
Page

**1** C-Profil  
 Profilé en C  
 C-profiel  
 C-section  
**1.880 mm**

**2** Querträger  
 Piètement  
 Voetplaat  
 Foot plate

**3** Aufhängeschiene  
 Rail d'accrochage  
 Ophangrail  
 Bin acceptor rail

**4** Platte  
 Plaque de renforcement  
 Versterkingsplaat  
 Reinforcement plate  
**68x24x4 mm**

**5** Schraube  
 Boulon  
 Bout  
 Bolt  
**M8x16**

**6** Mutter  
 Ecrou  
 Moer  
 Nut  
**M8**

**7** Schraube  
 Boulon  
 Bout  
 Bolt  
**M8x12**

**8** Stopfen  
 Embout  
 Afsluitkapje  
 End cap

**9** PVC-Klemmschiene  
 Rail protecteur en PVC,  
 à glisser sur les bords  
 PVC beschermings-  
 klemrail  
 PVC clamp-on protec-  
 tion rail

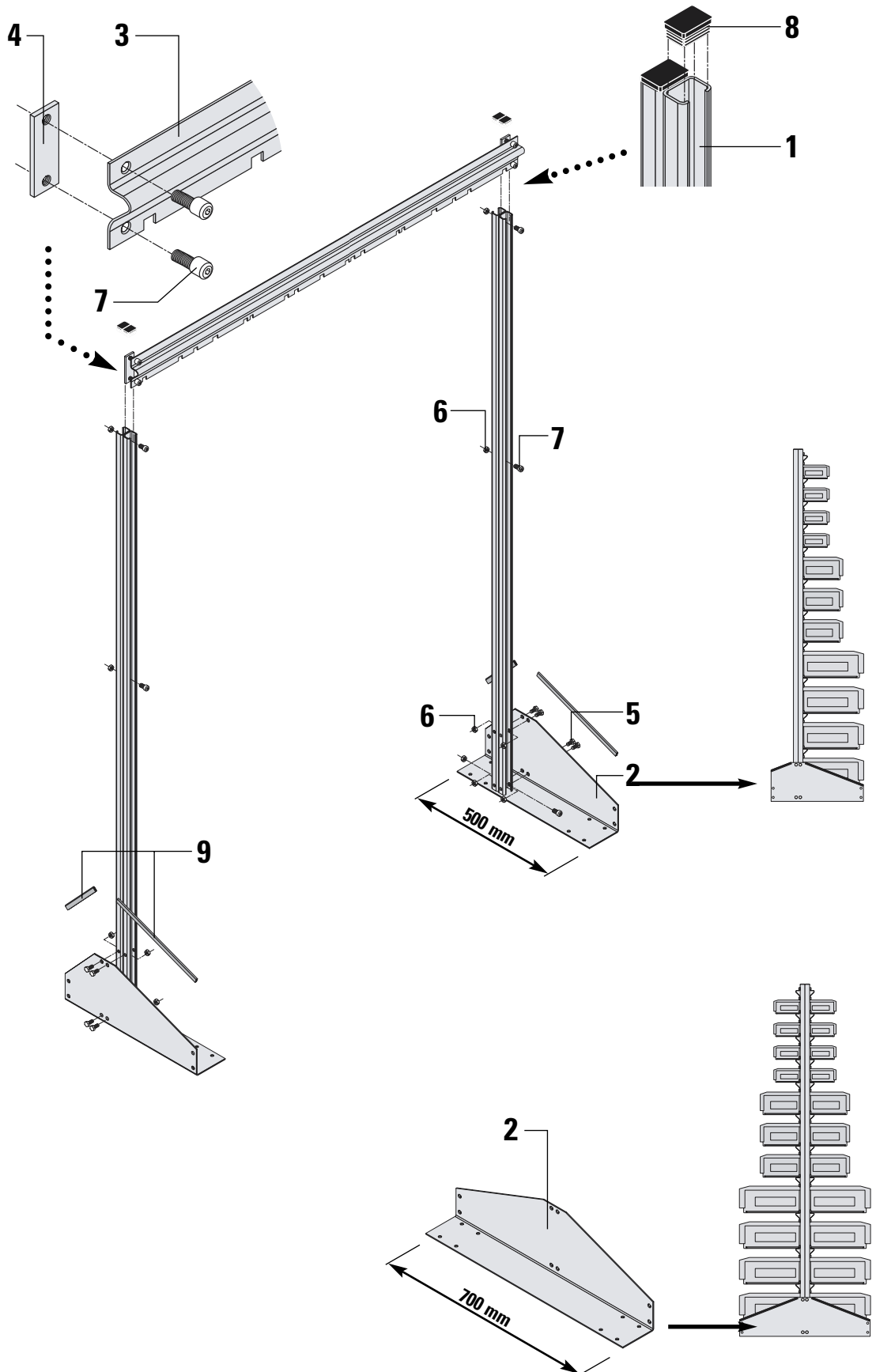

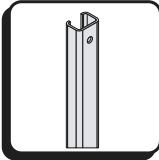

**C-Profil**  
**Profilés en C**  
**C-profielen**  
**C-sections**



Mutter  
 Ecrou  
 Moer  
 Nut  
**M8**

C-Profil  
 Profilé en C  
 C-profiel  
 C-section

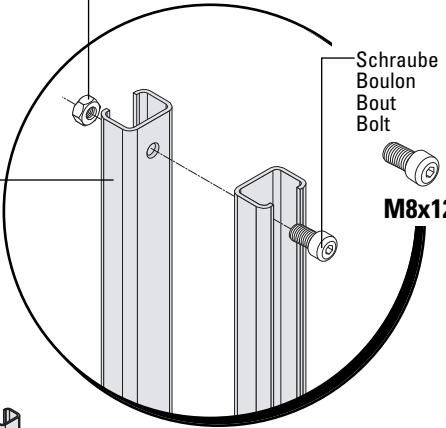

Schraube  
 Boulon  
 Bout  
 Bolt

**M8x12**

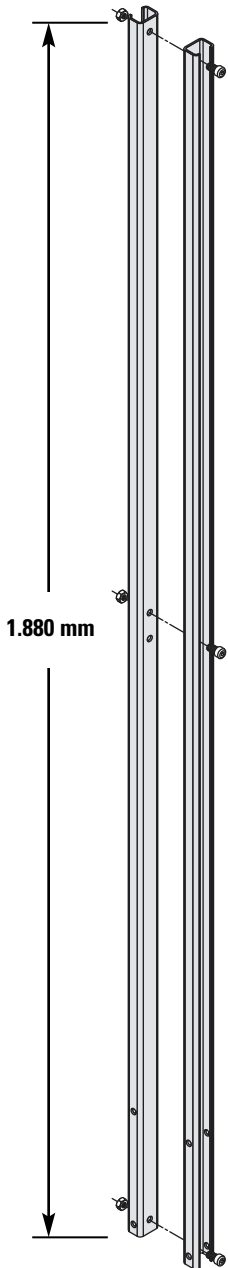

1.880 mm

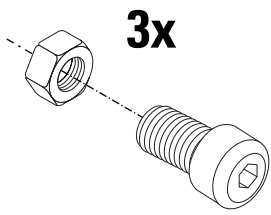

**3x**



**Querträger**  
**Piètement**  
**Voetplaat**  
**Foot plate**

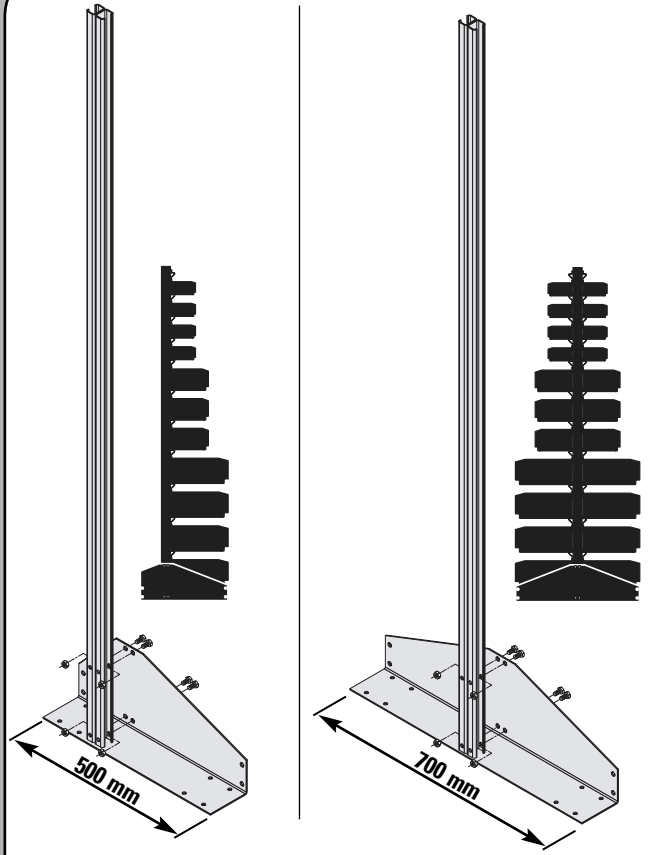
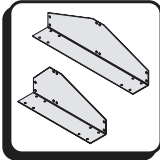

500 mm

700 mm

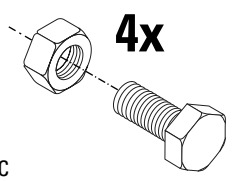

**4x**

Mutter  
 Ecrou  
 Moer  
 Nut  
**M8**

C-Profil  
 Profilé en C  
 C-profiel  
 C-section

Schraube  
 Boulon  
 Bout  
 Bolt

**M8x16**

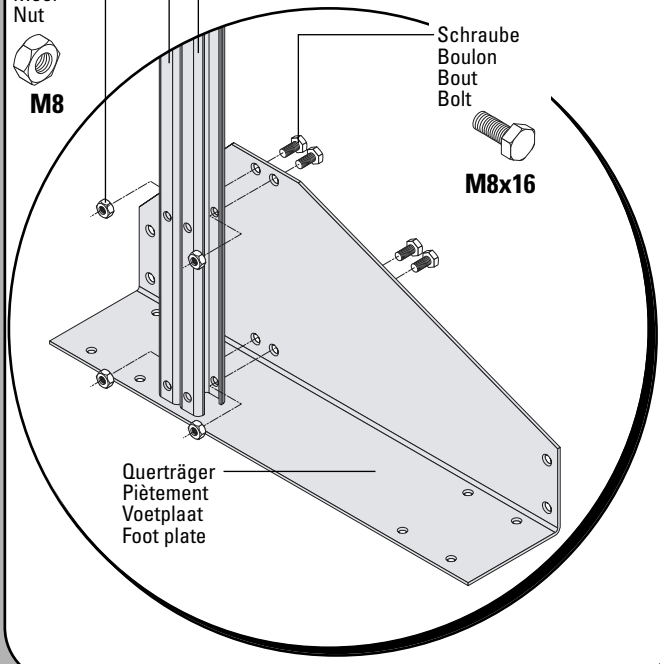

Querträger  
 Piètement  
 Voetplaat  
 Foot plate

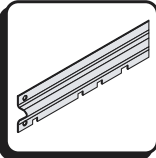

**Aufhängeschiene**  
**Rail d'accrochage**  
**Ophangrail**  
**Bin acceptor rail**



Aufhängeschiene  
 Rail d'accrochage  
 Ophangrail  
 Bin acceptor rail

Platte  
 Plaque  
 Plaat  
 Plate  
**68x24x4**

**1.**

Schraube  
 Boulon  
 Bout  
 Bolt  
**M8x12**

**max. 25 Nm**

**2.**

C-Profil  
 Profilé en C  
 C-profiel  
 C-section

**3.**

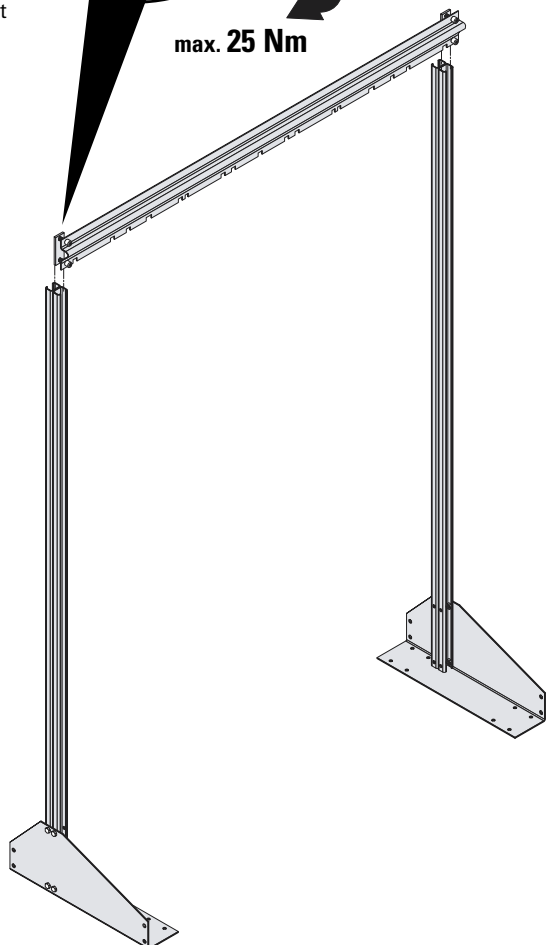

**Einteilung**  
**Positionnement**  
**Positionering**  
**Location**

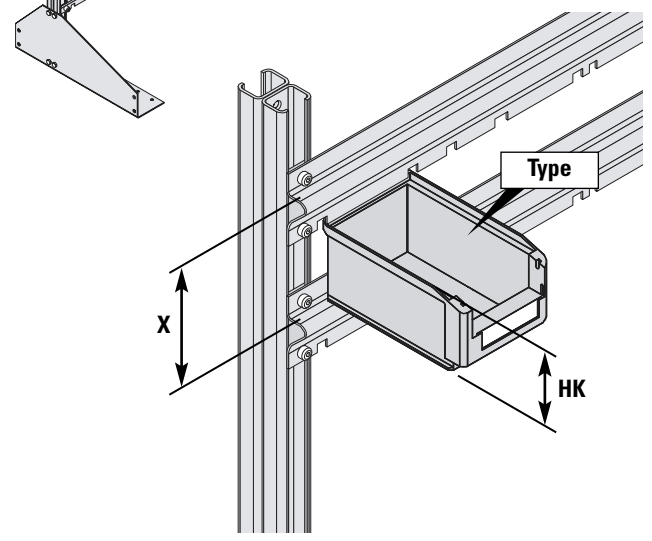
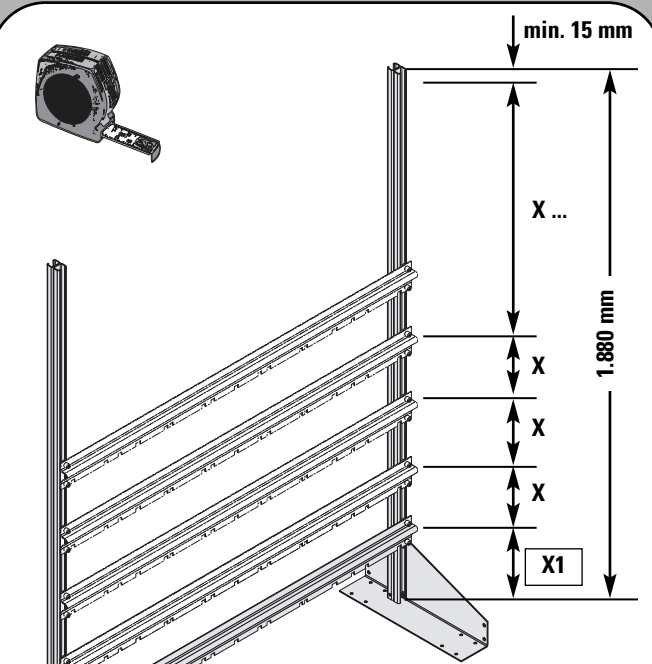

	Type	HK	X
	SK 1095	50 mm	95 mm
	SK 1610	75 mm	120 mm
	SK 2311	125 mm	170 mm
	SK 3521	145 mm	190 mm

**$X1 = 1.880 \text{ mm} - 15 \text{ mm} - \sum X$**



**Stopfen/Klemmschiene**  
**Embout/ Rail protecteur**  
**Afsluitkapje/Beschermingsrail**  
**End cap/Protection rail**



Stopfen  
 Embout  
 Afsluitkapje  
 End cap

C-Profil  
 Profilé en C  
 C-profiel  
 C-section

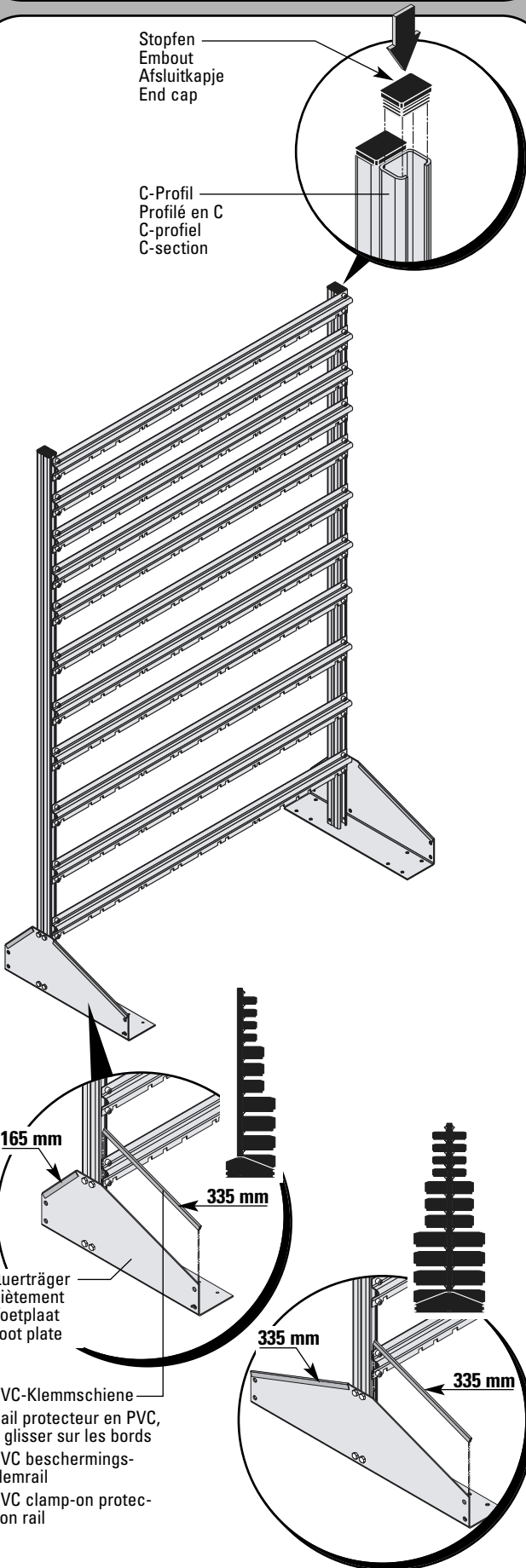

**Belastungen**  
**Capacité de charge**  
**Draagvermogen**  
**Load capacity**

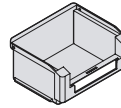

Type  
 »SK 1095«

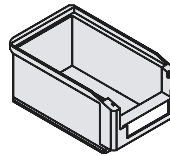

Type  
 »SK 1610«

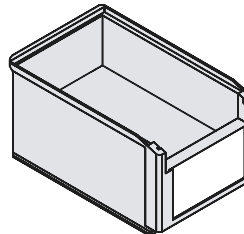

Type  
 »SK 2311«

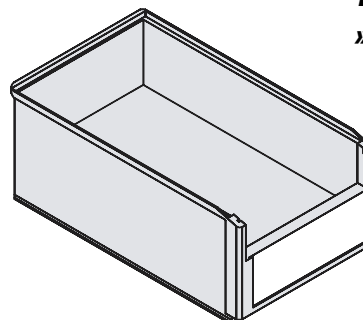

Type  
 »SK 3521«

