

BITO

Die pfiffige Lösung

Scheibenlagerung Stockage de pare-brises Opslag van voorruit Windscreen storage

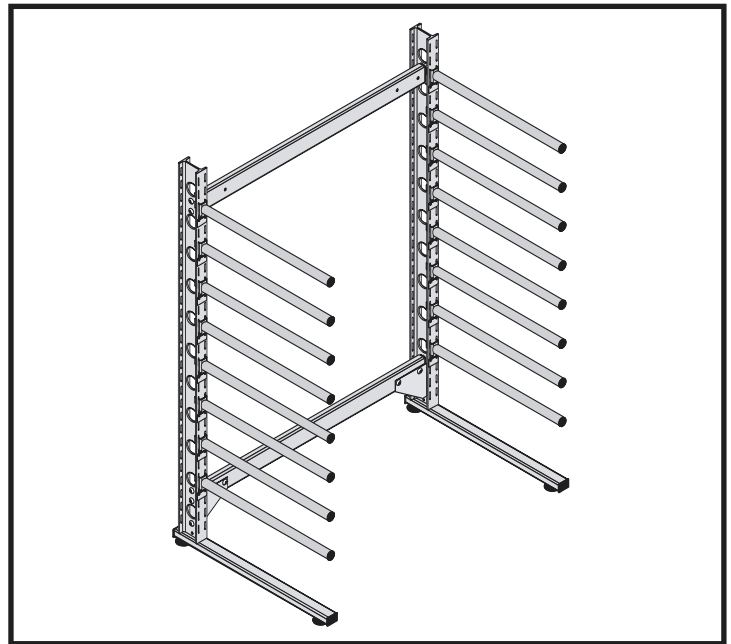

***Aufbau- und Betriebsanleitung
Instructions de montage et d'utilisation
Richtlijnen en montagehandleiding
Instructions for assembly and use***

Technische Änderungen vorbehalten. Modifications techniques réservées. Technische wijzigingen voorbehouden. Technical modifications reserved.

Scheibenlagerung

Stand
06-2004

DIN EN ISO 9001

Inhalt / Sommaire / Inhoud / List of contents

Unbedingt beachten / Réglementations importantes /
Belangrijke richtlijnen / Important regulations



Sicherheitsvorschriften
Consignes de sécurité
Veiligheidsvoorschriften
Accident prevention regulations

3



Nivellierung
Mise à niveau
Nivellering
Levelling

3

Übersicht / Sommaire / Inhoud / List of contents

4

Montage / Assembly



Verstellfuß
Vérin de mise à niveau
Nivelleervoetje
Levelling foot

5



Stopfen
Embout
Afsluitkapje
End cap

5



Doppelseitige Bauweise
Configuration double face
Dubbelzijdige opstelling
Double-sided configuration

6-7



Horizontalverbinder
Entretoise
Stabiliteitsligger
Connector beam

8



Knotenblech
Plaque de renforcement
Versterkingsplaat
Reinforcement plate

9



Dorn
Bras
Draagarm
Arm

10

Belastungen / Capacité de charge /
Draagvermogen / Load capacity

11



Bei Bedarf bestellen
Peut être fourni sur demande
Levering op aanvraag mogelijk
Can be supplied upon request

Sicherheitsvorschriften / Consignes de sécurité /
Veiligheidsvoorschriften / Accident prevention regulations

BGR 234 (ZH 1/428)

Richtlinien für Lagereinrichtungen und -geräte der
Berufsgenossenschaften.

En tant que responsable de l'exploitation, veuillez respecter
les réglementations de sécurité en vigueur.

Gebruikers dienen rekening te houden met de geldende
nationale veiligheidsvoorschriften inzake magazijninrichtingen.

Users of the installation have to observe the relevant health
and safety regulations.

Nivellierung / Mise à niveau / Nivellering / Levelling

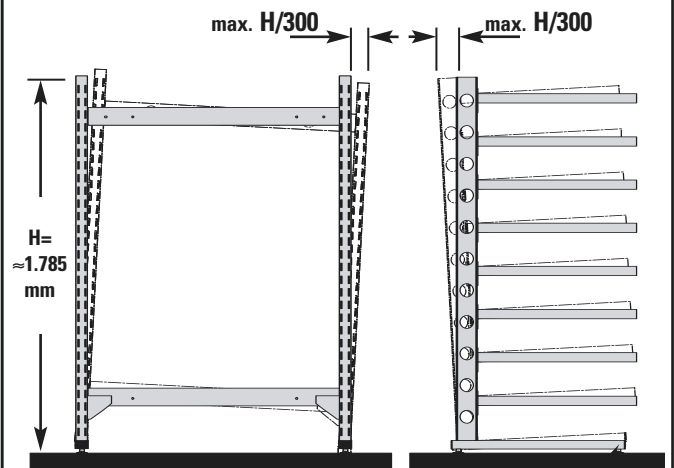

Verstellfuß
Vérin de mise à niveau
Nivelleervoetje
Levelling foot

! Kontermutter anziehen
Bloquer par contre-écrou
Contraoer vastschroeven
Tighten counter nut



Übersicht
Sommaire
Inhoud
List of contents

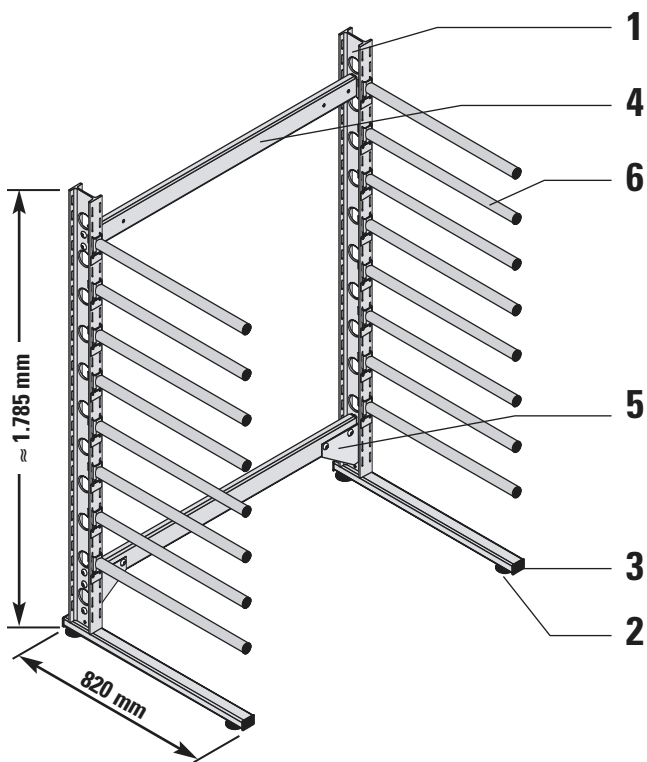

Seite
Page
Pagina
Page

1	Ständer Montant Staander Column	5
2	Verstellfuß Vérin de mise à niveau Nivelleervoetje Levelling foot	5
3	Stopfen Embout Afsluitkapje End cap	5
4	Horizontalverbinder Entretoise Stabiliteitsligger Connector beam	8
5	Knotenblech Plaque de renforcement Versterkingsplaat Reinforcement plate	9
6	Dorn Bras Draagarm Arm	10



Verstellfuß
Vérin de mise à niveau
Nivelleervoetje
Levelling foot

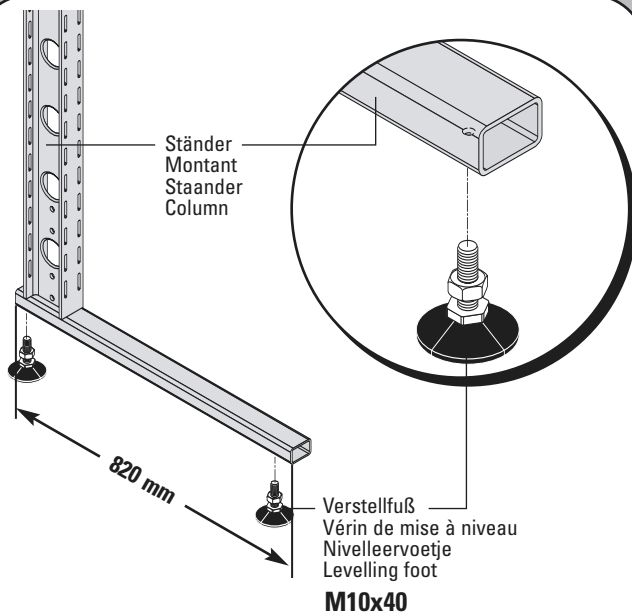
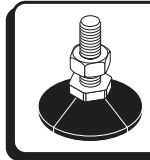

Doppelseitige Bauweise Seite 6-7 beachten!
Voir configuration double face sur pages 6-7!
Zie dubbelzijdige opstelling op pagina's 6-7!
See double-sided configuration on pages 6-7!



Stopfen
Embout
Afsluitkapje
End cap

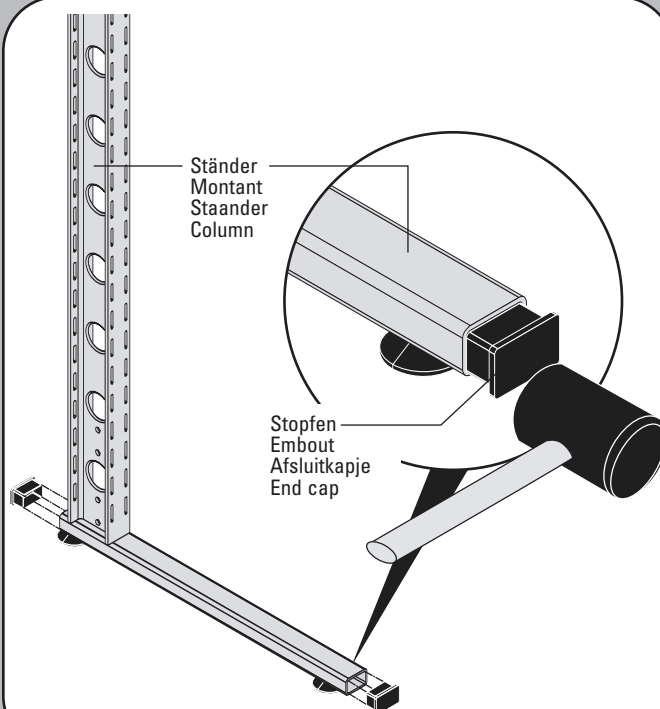
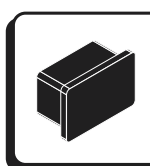

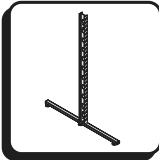

Doppelseitige Bauweise
Configuration double face
Dubbelzijdige opstelling
Double-sided configuration

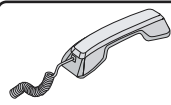

Bei Bedarf bestellen
 Peut être fourni sur demande
 Levering op aanvraag mogelijk
 Can be supplied upon request

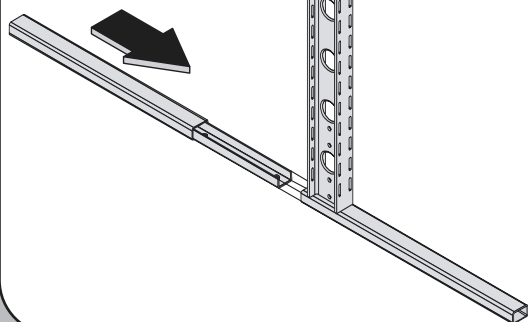
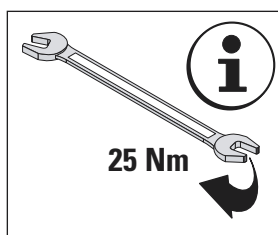
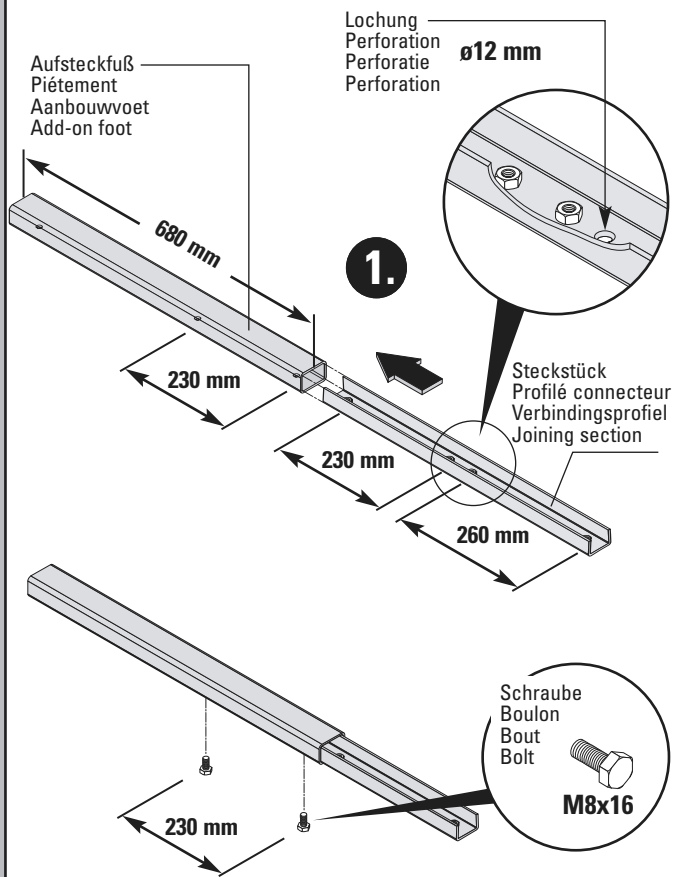

Doppelseitige Bauweise
Configuration double face
Dubbelzijdige opstelling
Double-sided configuration

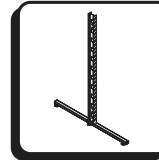

3.

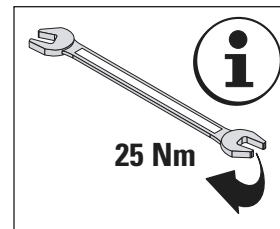
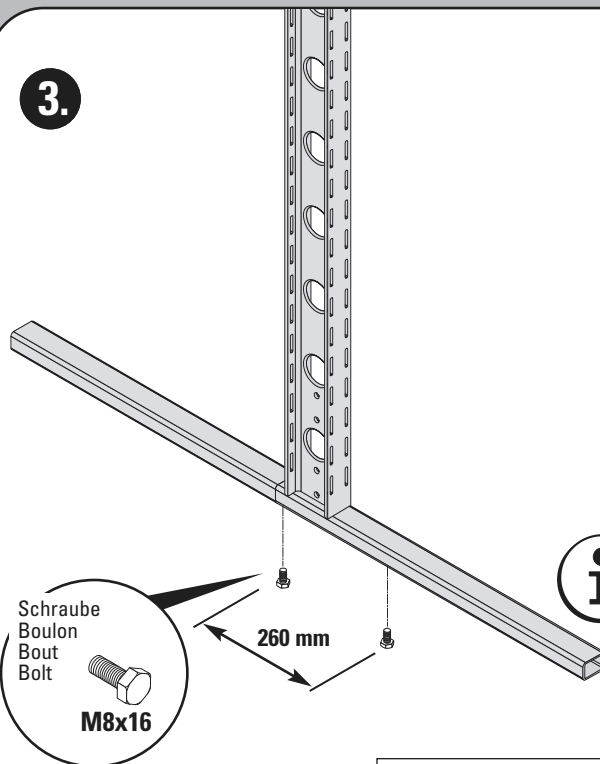

4.

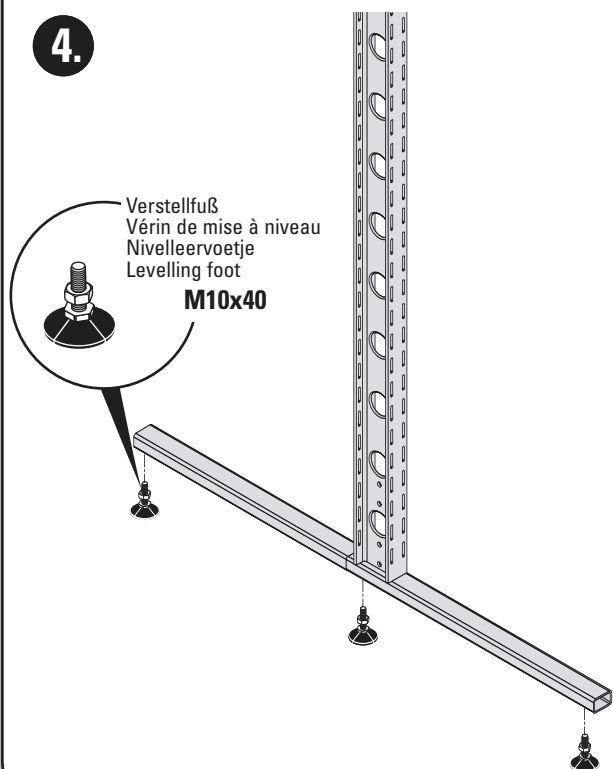

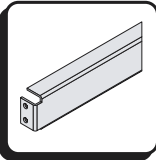

Horizontalverbinder
Entretoise
Stabilitetsligger
Connector beam

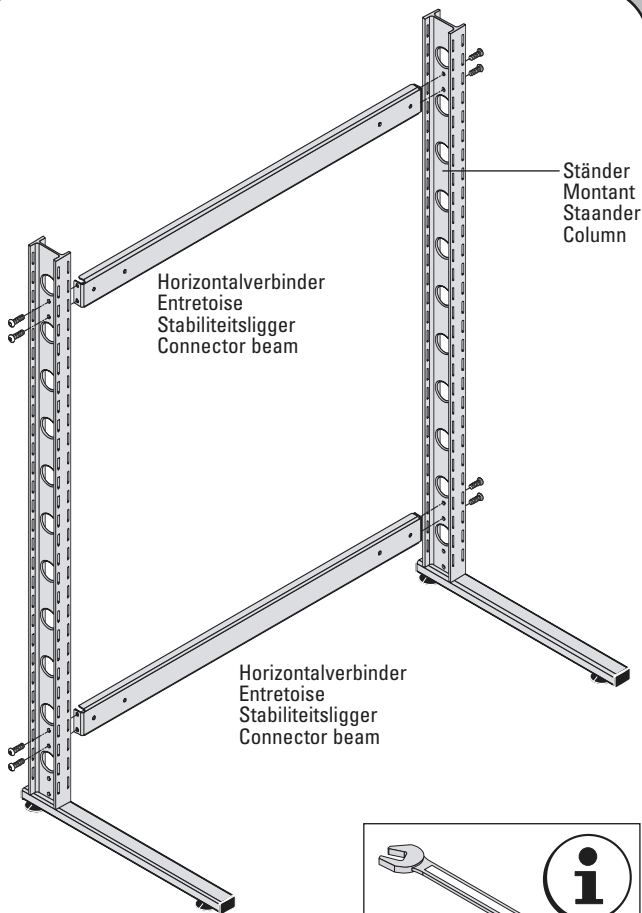

Ständer
 Montant
 Staander
 Column

Horizontalverbinder
 Entretoise
 Stabilitetsligger
 Connector beam

Horizontalverbinder
 Entretoise
 Stabilitetsligger
 Connector beam

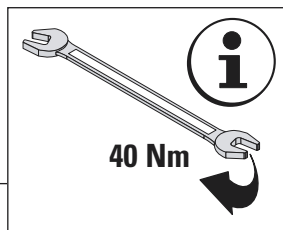

40 Nm

Ansicht von hinten
 Vue côté arrière
 Aanzicht rugzijde
 View on rear side

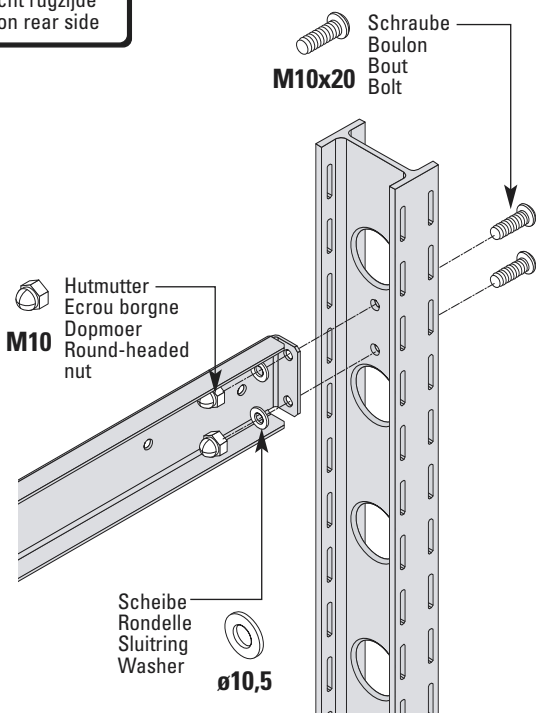

Schraube
 Boulon
 Bout
 Bolt
M10x20

Hutmutter
 Ecrou borgne
 Dopmoer
 Round-headed nut
M10

Scheibe
 Rondelle
 Sluiring
 Washer
 $\phi 10,5$



Knotenblech
Plaque de renforcement
Versterkingsplaat
Reinforcement plate

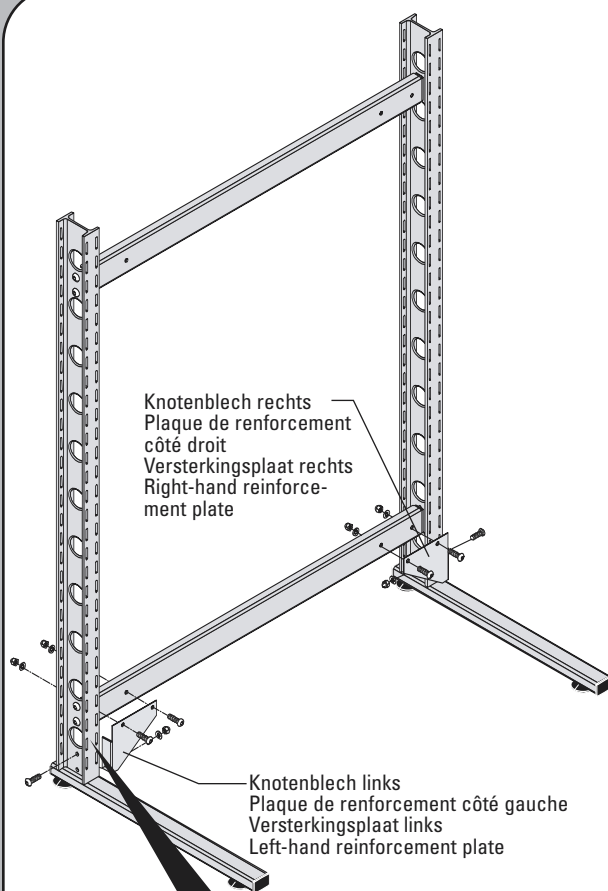
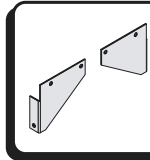

Knotenblech rechts
 Plaque de renforcement
 côté droit
 Versterkingsplaat rechts
 Right-hand reinforcement plate

Knotenblech links
 Plaque de renforcement
 côté gauche
 Versterkingsplaat links
 Left-hand reinforcement plate

Hutmutter
 Ecrou borgne
 Dopmoer
 Round-headed nut

M10

Scheibe
 Rondelle
 Sluiring
 Washer
 $\phi 10,5$

Schraube
 Boulon
 Bout
 Bolt
M10x20

Ansicht von hinten
 Vue côté arrière
 Aanzicht rugzijde
 View on rear side

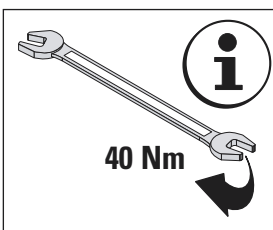

40 Nm

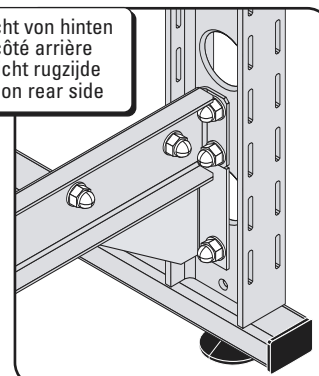

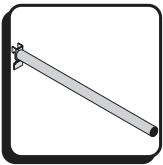

**Dorn
Bras
Draagarm
Arm**



Mutter
Ecrou
Moer
Nut
M6
Type Tensilock



Schraube
Boulon
Bout
Bolt
M6x25

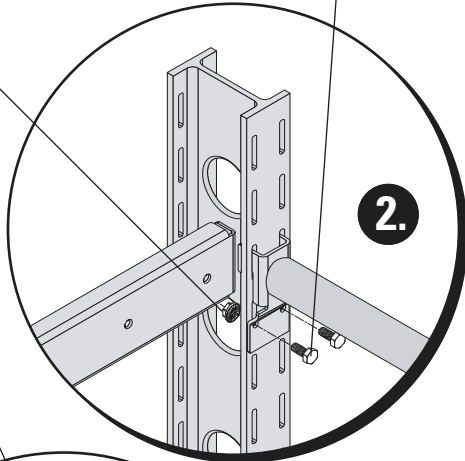

Ständer
Montant
Staander
Column

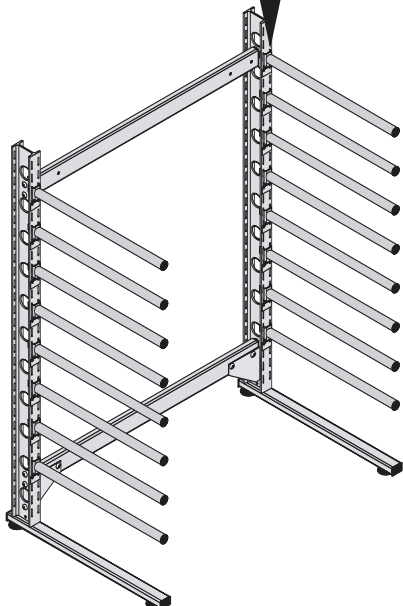
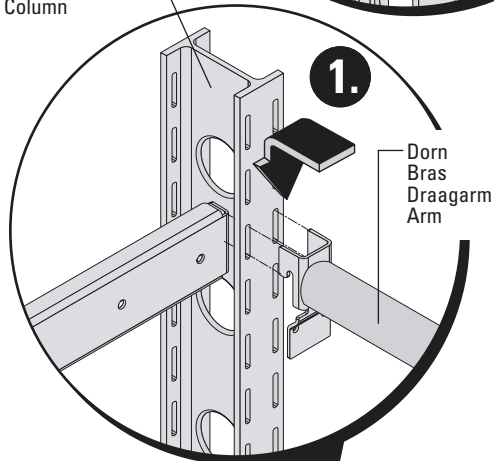

**Belastungen
Capacité de charge
Draagvermogen
Load capacity**

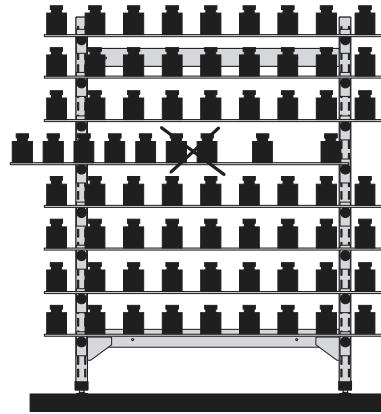

= max. 20 kg
= max. 20 kg
= max. 20 kg
= max. 20 kg
= max. 20 kg
= max. 20 kg
= max. 20 kg
= max. 20 kg

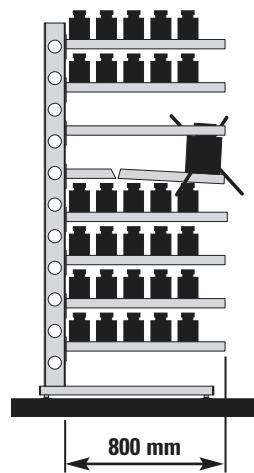

**Gleichmäßig verteilte Last!
Charges uniformément réparties!
Gelijkmatig verdeelde belasting!
Evenly distributed loads!**

