

Regalwagen RW 7N

Innovative Storage Solutions

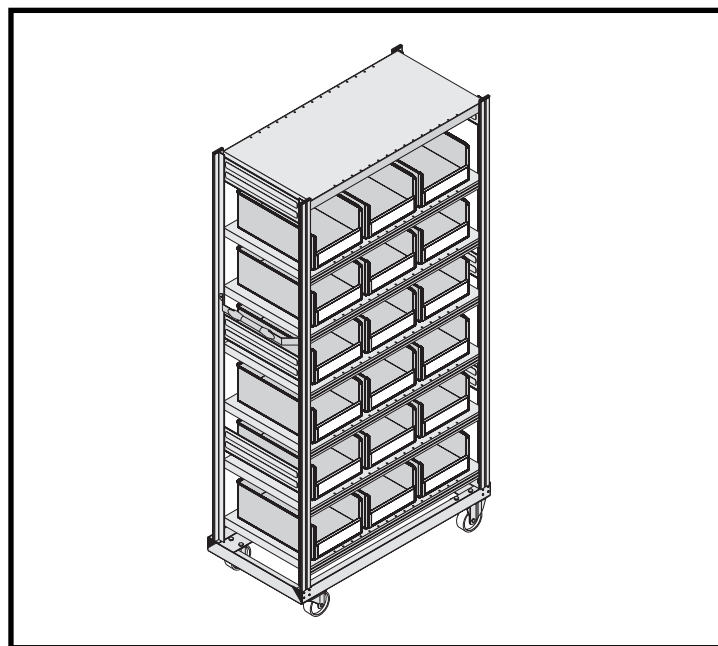

Regalwagen Rayonnage mobile Verrijdbare legbordstelling Mobile shelving



*Aufbau- und Betriebsanleitung
Instructions de montage et d'utilisation
Richtlijnen en montagehandleiding
Instructions for assembly and use*

RW 7N

Technische Änderungen vorbehalten. Modifications techniques réservées. Technische wijzigingen voorbehouden. Technical modifications reserved.

Stand
04-2003

DIN EN ISO 9001

Übersicht / Aperçu / Overzicht / Survey

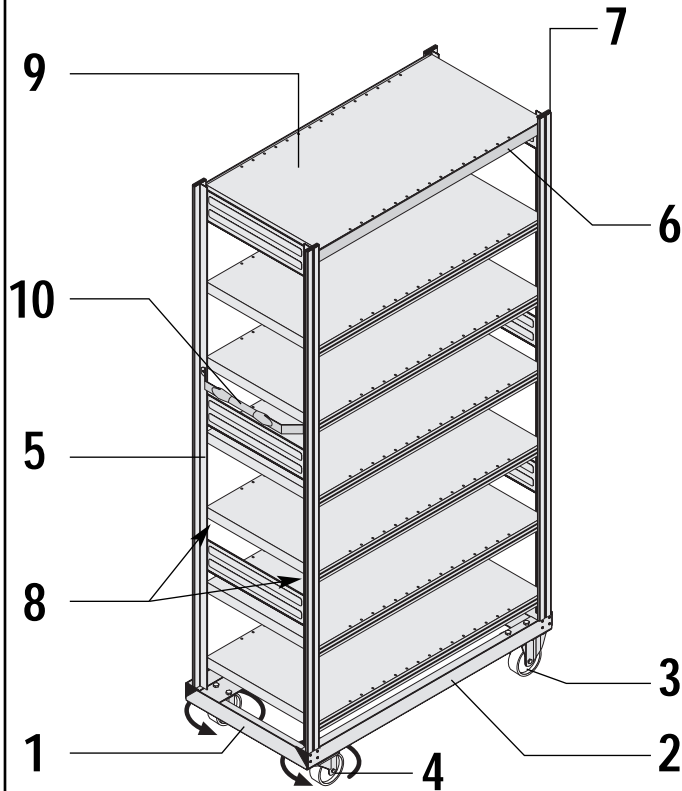

Pos.



Seite
Page
Pagina
Page

1	Querträger Profilé chassis côté court Dwarsdrager Short side frame section		5
2	Längsträger Profilé chassis côté long Langsdrager Long side frame section		5
3	Bockrolle Roue fixe Bokwiel Fixed castor		5
4	Lenkrolle Roue pivotante Zwenkwiel Swivel castor		5
5	Stützrahmen Echelle Stellingkader Frame		6
6	Traverse Lisse Ligger Beam	SLT	7
7	Stopfen Embout Afsluitkapje Protective cap		7
8	Fachbodenträger Support tablettes Legbordhaakje Shelf clip	SFT1	8
9	Fachboden Tablette Legbord Shelf		9
10	Griff Poignée de manoeuvre Duwbeugel Push and pull handle		9

Inhalt / Sommaire / Inhoud / List of contents

Seite
Page
Pagina
Page

Unbedingt beachten Réglementations importantes Belangrijke richtlijnen Important regulations	4	
---	---	--



Sicherheitsvorschriften
Consignes de sécurité
Veiligheidsvoorschriften
Accident prevention regulations

4

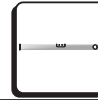

Nivellierung
Mise à niveau
Nivellerung
Levelling

4



Sicherheitshinweis
Instructions de sécurité pour l'emplacement
Opmerkingen voor een veilige handtering
Instructions for safe handling

4

Montage
Montage
Montage
Assembly

5-9



# 1	Querträger Profilé chassis côté court Dwarsdrager Short side frame section	5
# 2	Längsträger Profilé chassis côté long Langsdrager Long side frame section	5
# 3	Bockrolle Roue fixe Bokwiel Fixed castor	5
# 4	Lenkrolle Roue pivotante Zwenkwiel Swivel castor	5
# 5	Stützrahmen Echelle Stellingkader Frame	6
# 6	Traverse Lisse Ligger Beam	7
# 7	Stopfen Embout Afsluitkapje Protective cap	7
# 8	Fachbodenträger Support tablettes Legbordhaakje Shelf clip	8
# 9	Fachboden Tablette Legbord Shelf	9
# 10	Griff Poignée de manoeuvre Duwbeugel Push and pull handle	9

Belastungen
Capacité de charge
Draagvermogen
Load capacity

10-11





Sicherheitsvorschriften
Consignes de sécurité
Veiligheidsvoorschriften
Accident prevention regulations



BGR 234 (ZH 1/428)

Richtlinien für Lagereinrichtungen und -geräte der Berufsgenossenschaften.

En tant que responsable de l'exploitation, veuillez respecter les réglementations de sécurité en vigueur.

Gebruikers dienen rekening te houden met de geldige nationale veiligheidsvoorschriften inzake magazijninrichtingen.

Users of the installation have to observe the relevant health and safety regulations.

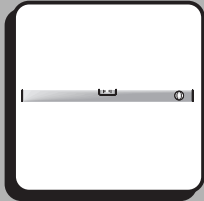

Nivellierung
Mise à niveau
Nivellering
Levelling

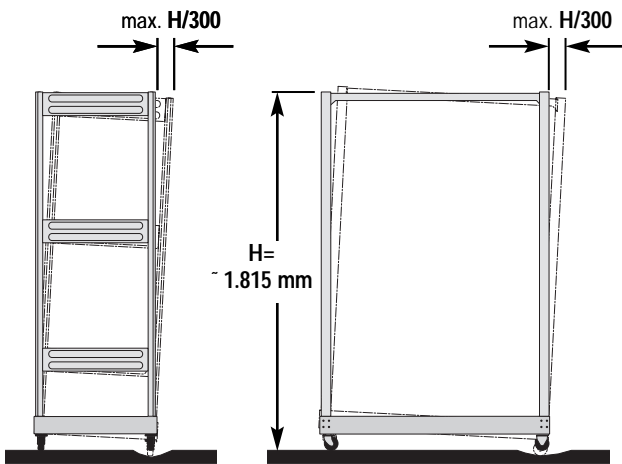

! **Auf Bodenunebenheiten achten**
Attention aux inégalités du sol
Let op vloeroneffenheden
Take possible floor unevenness into account



Sicherheitshinweis
Instructions de sécurité
Opmerkingen voor een veilige handtering
Instructions for safe handling

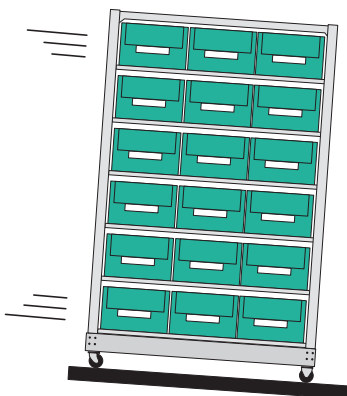

Auf schiefen Boden achten!

Ne pas positionner sur sols en pente!

Niet op schuine vloeren plaatsen!

Do not place on sloping floors!



Rahmenmontage
Montage du châssis
Montage onderstel
Frame assembly

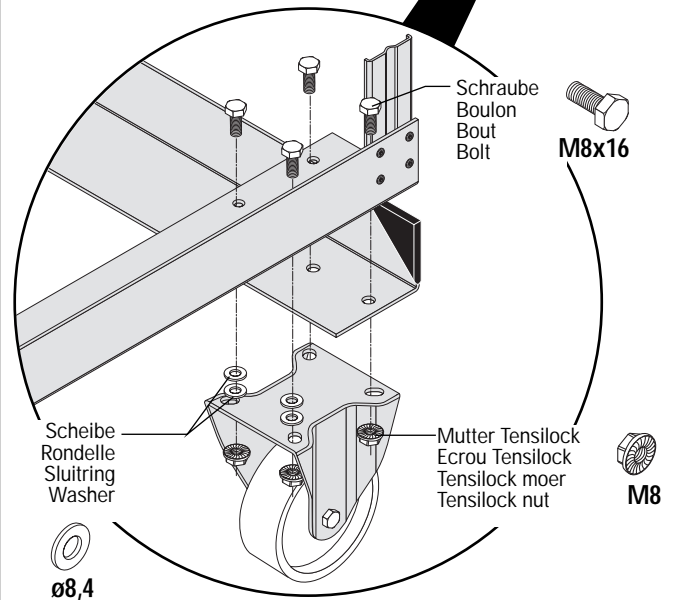
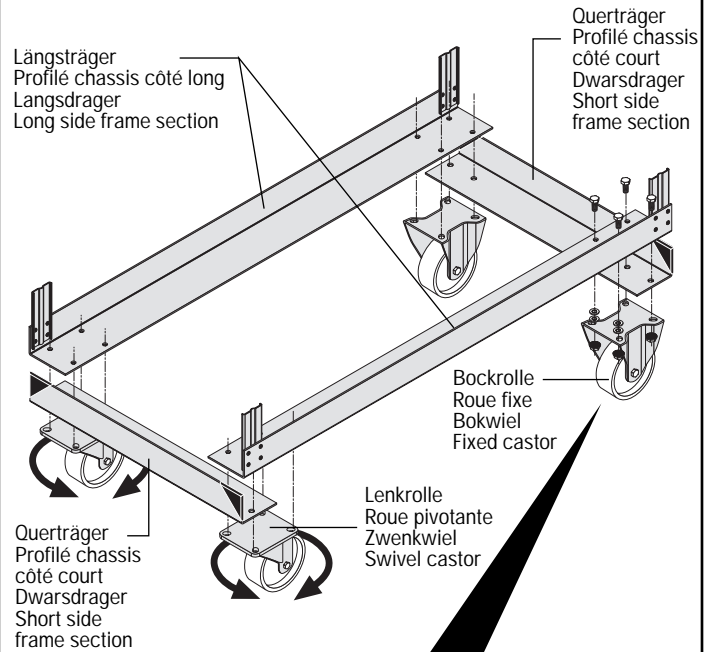
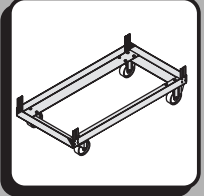

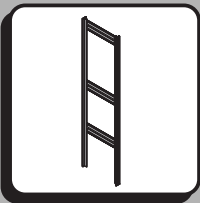

Stützrahmen
Echelle
Stellingkader
Frame

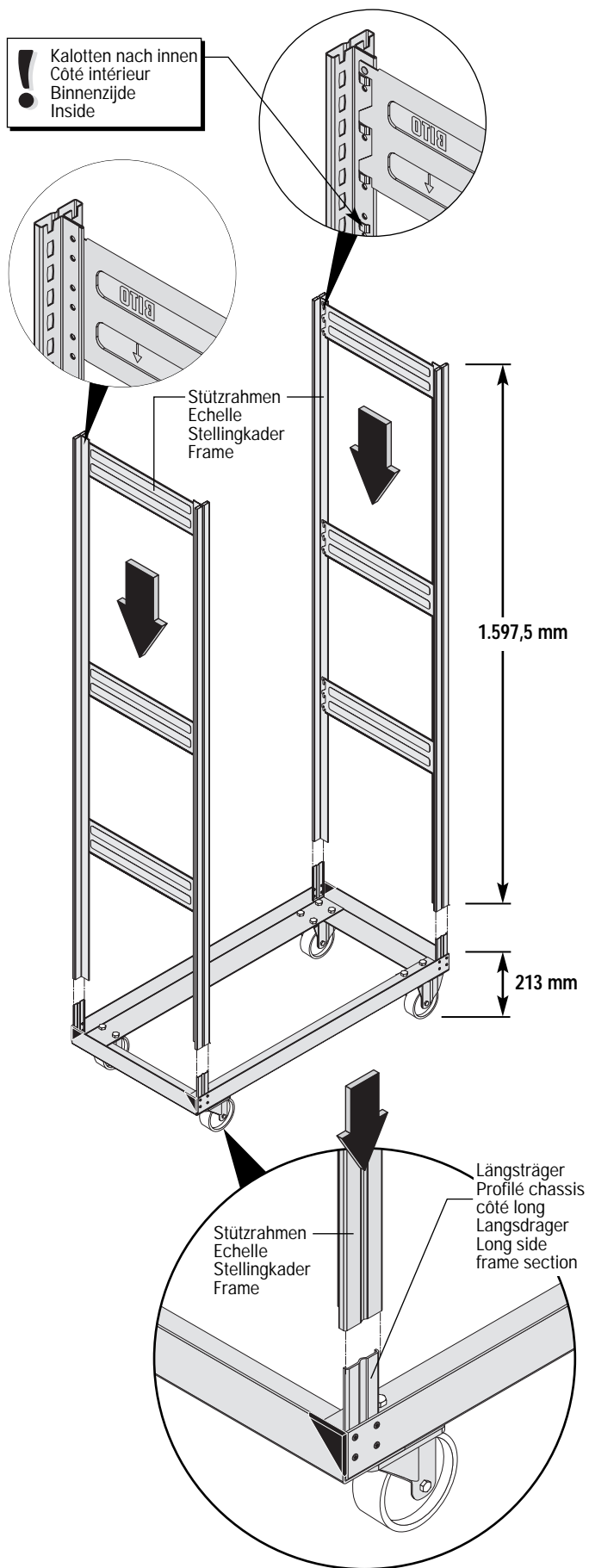

Traverse
Lisse
Ligger
Beam

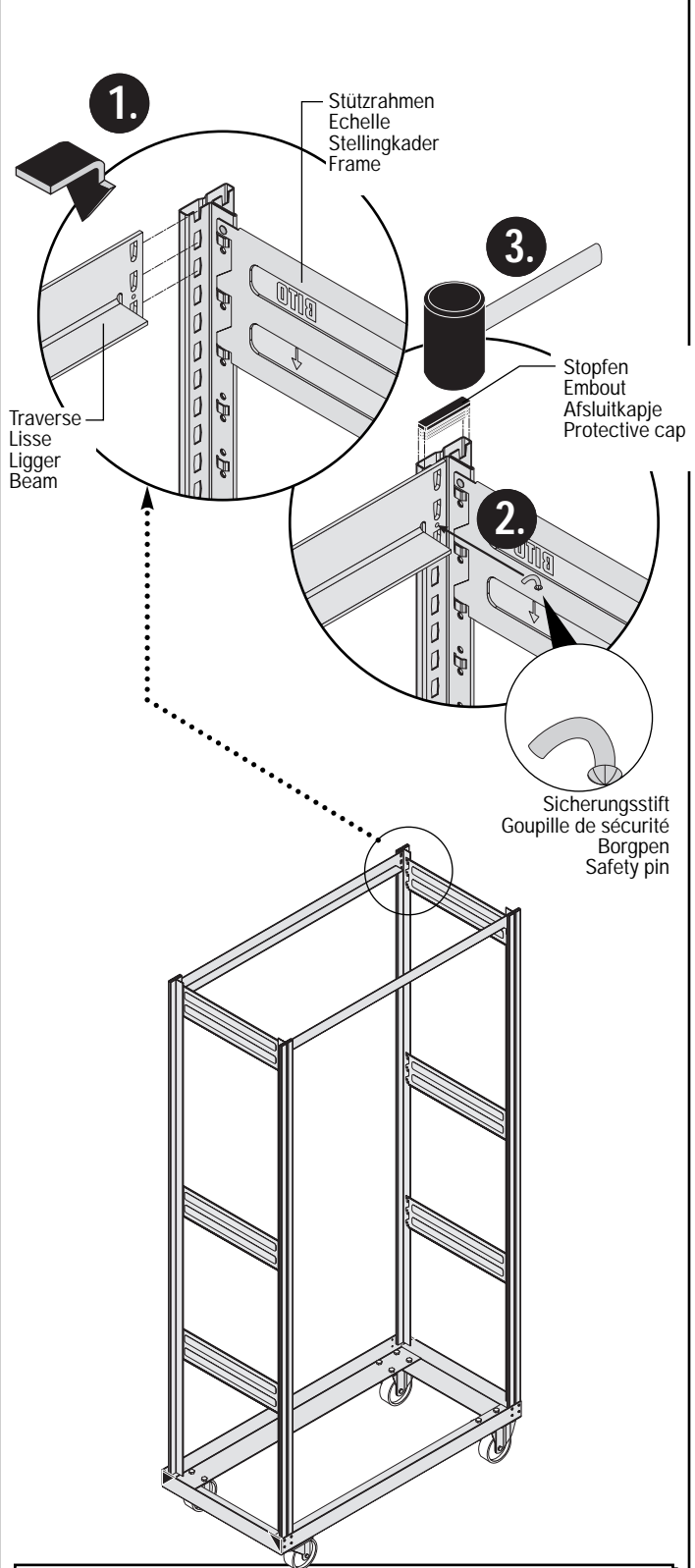
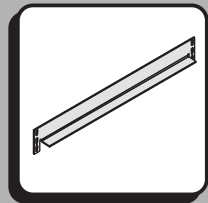

! Nach dem Einhängen ist **jede Lasche** der Traverse sofort mit **einem** Sicherungsstift zu sichern.
Après avoir emboîté une lisse bloquer immédiatement **chaque** connecteur par **une** goupille de sécurité.

! Ligger inhaken en onmiddellijk beveiligen tegen uittliften door **één** borgpen in **iedere inhaakverbinding** in te haken.
Hook beam into uprights and immediately secure **each** connector by inserting **one** safety pin.

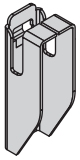

Fachbodenträger
Support tablettes
Legbordhaakje
Shelf clip

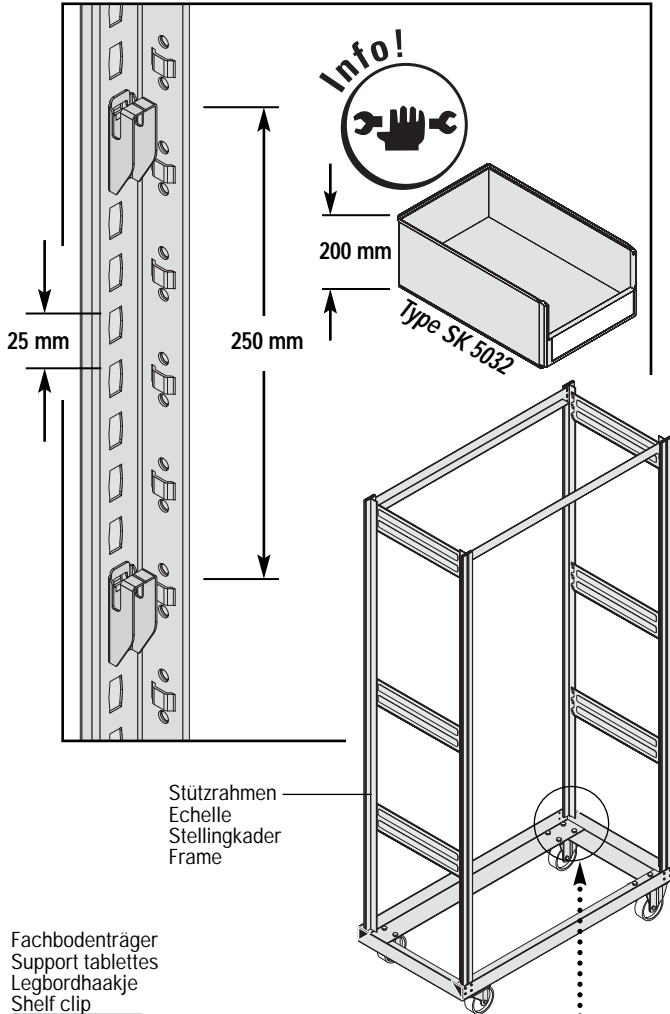

Fachbodenträger
Support tablettes
Legbordhaakje
Shelf clip

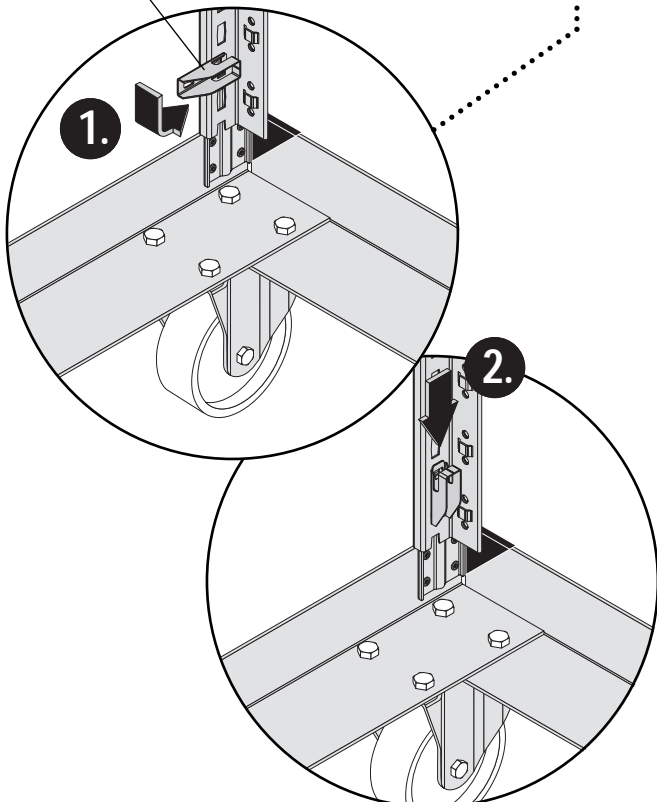

Fachboden
Tablette
Legbord
Shelf

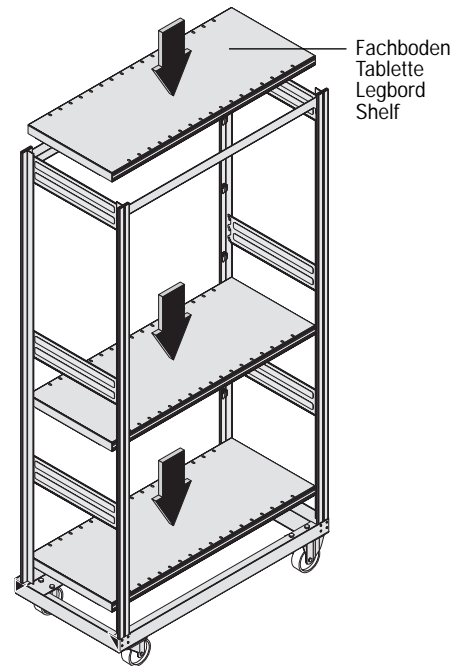
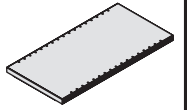

Griff
Poignée de manoeuvre
Duwbeugel
Push and pull handle

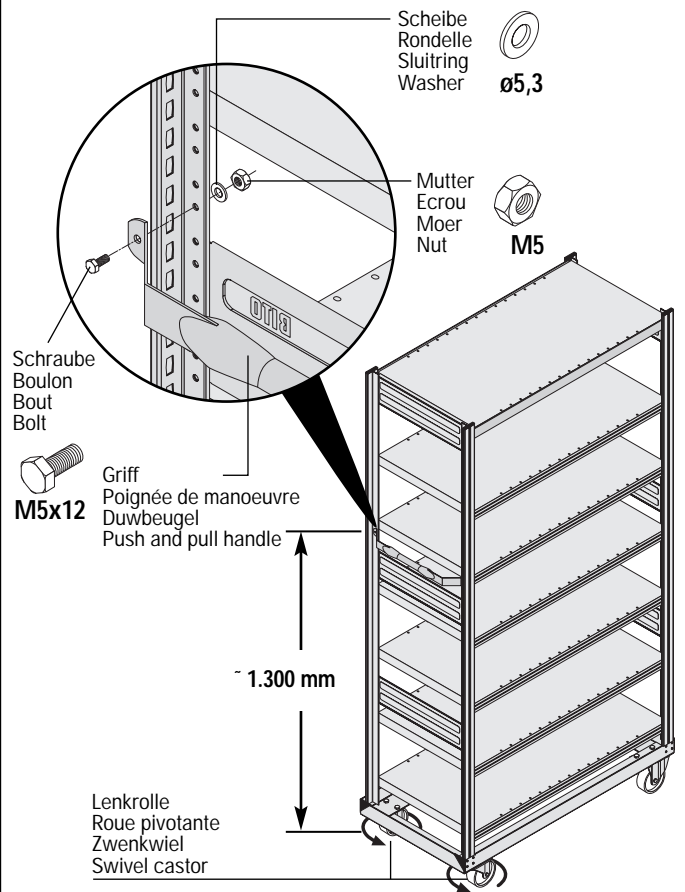
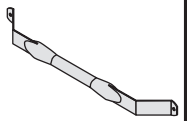



Belastungen
 Capacité de charge
 Draagvermogen
 Load capacity

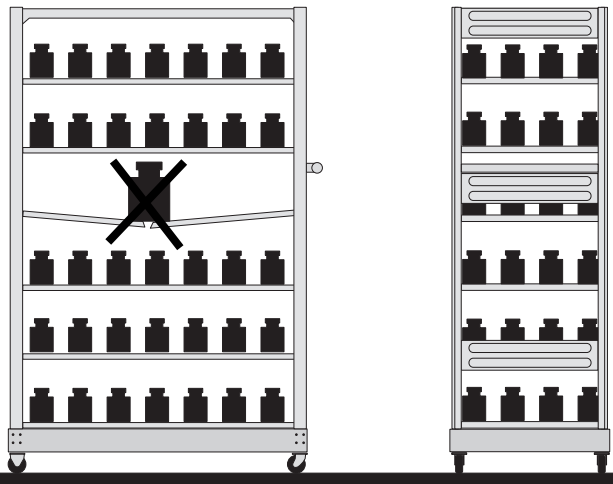

! Gleichmäßig verteilte Last!
 Charges uniformément réparties!
 Gelijkmatic verdeelde belasting!
 Evenly distributed loads! **!**

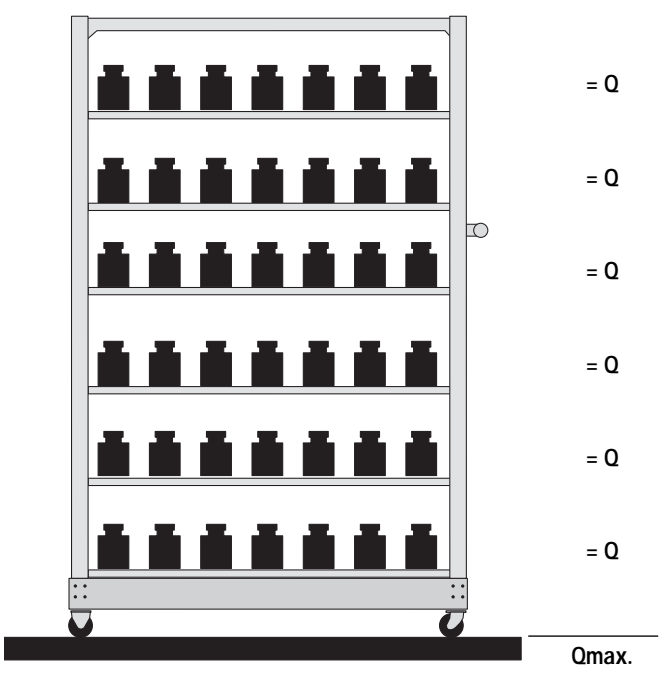

! $\sum Q \leq Q_{max}$ **!**



Belastungen
 Capacité de charge
 Draagvermogen
 Load capacity



Bodenbelastung
 Charge par tablette
 Draagvermogen per legbord
 Shelf load

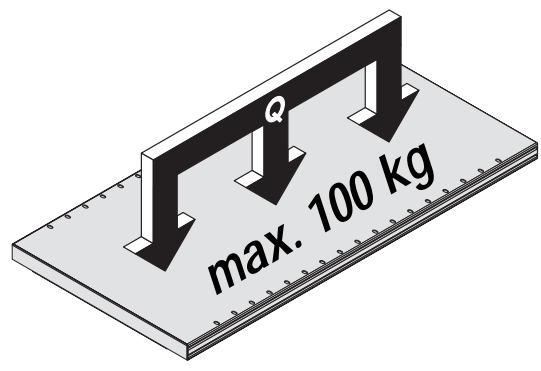

Gesamtlast
 Capacité de charge totale
 Draagvermogen per stellingeenheid
 Total load capacity

! $\sum Q \leq Q_{max}$ **!**

$Q_{max.} = 500 \text{ kg}$

