

BITO

Die pfiffige Lösung

Arbeitstisch Etabli Werkbank Workbench

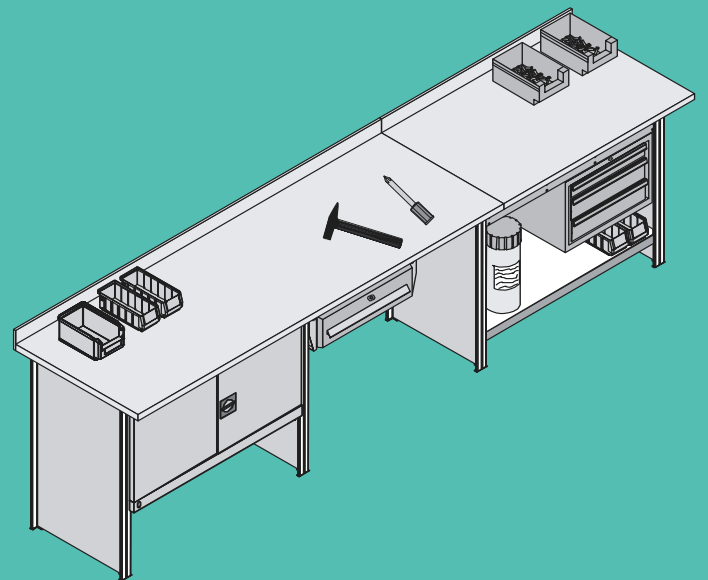

**Aufbau- und Betriebsanleitung
Instructions de montage et d'utilisation
Richtlijnen en montagehandleiding
Instructions for assembly and use
AT**





















Technische Änderungen vorbehalten. Modifications techniques réservées. Technische wijzigingen voorbehouden. Technical modifications reserved.

AT

Stand
03-2002

DIN EN ISO 9001

Inhalt / Sommaire / Inhoud / List of contents

Unbedingt beachten Réglémentations importantes Belangrijke richtlijnen Important regulations	3	
 Sicherheitsvorschriften Consignes de sécurité Veiligheidsvoorschriften Accident prevention regulations	3	
 Übersicht Aperçu Overzicht Survey	3	
Montage Montage Montage Assembly	4-19	
 Stützrahmen-Seitenwand Paroi latérale Zijwand Side cladding	4	
 Stützrahmen Echelle Stellingkader Frame	5-6	
 Feldansicht Structure de base Onderstel Stand	7	
 Rückwand-Vollblech Fond tôle Volle rugwand Closed back cladding	8-9	
 Traverse Longeron Ligger Beam	9	
 Fachboden Tablette Legbord Shelf	10	
 Arbeitsplatte Plateau Werkblad Top	11	
 Abmessungen Dimensions Afmetingen Dimensions	12	
 Vorbohren Perçage préalable avec un diamètre inférieur Voorboren Pre-drilling with a smaller diameter	13	
 Verbindungsplatte Plaque d'accouplement Verbindingsplaat Connector plate	13	
 Bordbrett Rebord Boordplank Back board	14	
 Schublade Tiroir Schuiflade Drawer	15	
 Flügeltüren Portes battantes Vleugeldeuren Hinged doors	16-17	
 Schubladenblock Bloc tiroir Ladenblok Drawer unit	18	
 Dübel Cheville Vloeranker Floor anchor	19	
 Unterlegblech Cale Nivelleerplaat Levelling plate	19	



Sicherheitsvorschriften Consignes de sécurité Veiligheidsvoorschriften Accident prevention regulations



ZH 1/428 "Richtlinien für Lagereinrichtungen und -geräte der Berufsgenossenschaften".

En tant que responsable de l'exploitation, veuillez respecter les réglementations de sécurité en vigueur.

Gebruikers dienen rekening te houden met de geldige nationale veiligheidsvoorschriften inzake magazijninrichtingen.

Users of the installation have to observe the relevant health and safety regulations.



Übersicht Aperçu Overzicht Survey

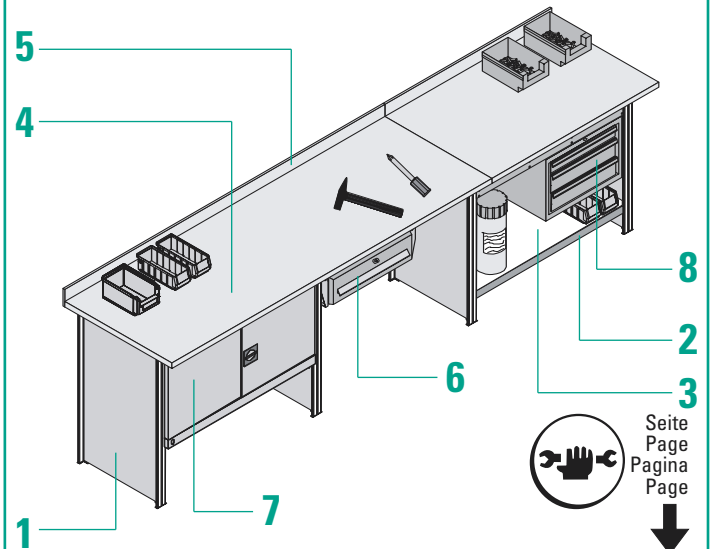

1	Stützrahmen Echelle Stellingkader Frame	4-6
2	Traverse Longeron Ligger Beam	9
3	Fachboden Tablette Legbord Shelf	10
4	Arbeitsplatte Plateau Werkblad Top	11-12
5	Bordbrett Rebord Boordplank Back board	14
6	Schublade Tiroir Schuiflade Drawer	15
7	Flügeltüren Portes battantes Vleugeldeuren Hinged doors	16-17
8	Schubladenblock Bloc tiroir Ladenblok Drawer unit	18

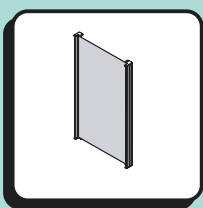

Stützrahmen-Seitenwand
Paroi latérale
Zijwand
Side cladding

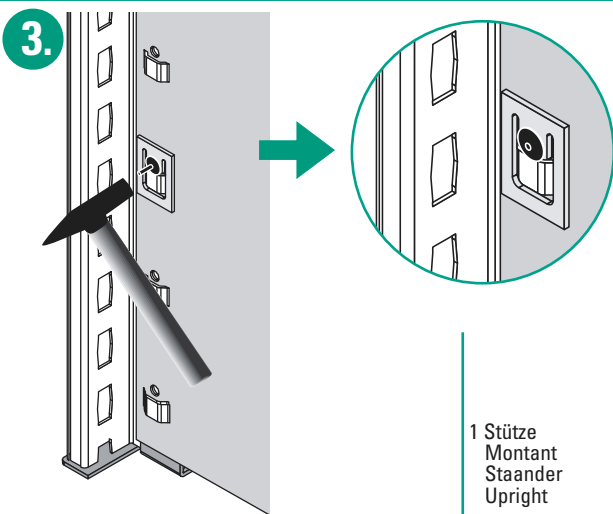
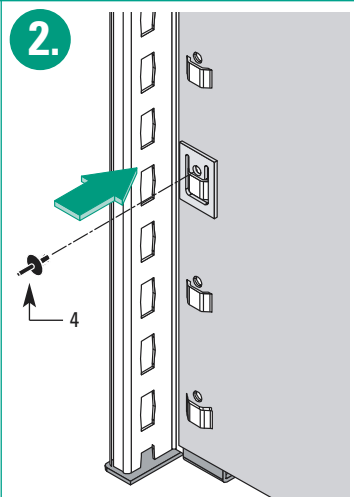
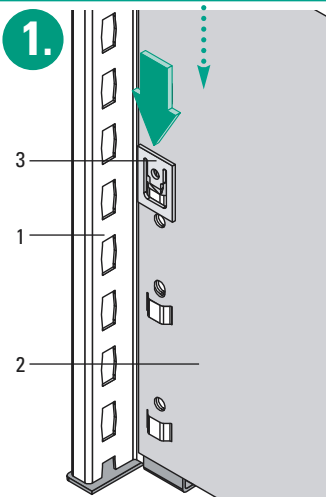
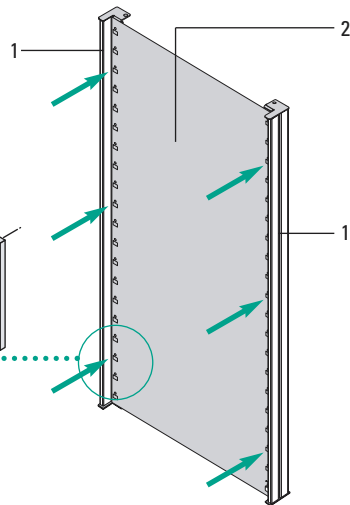
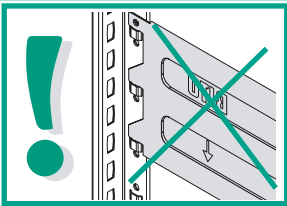

1 Stütze
 Montant
 Staander
 Upright

2 Seitenwand
 Vollblech/Lochblech
 Paroi latérale tôle/
 perforée
 Volle/geperforeerde
 zijwand
 Closed/perforated
 side cladding

3 Halteklammer
 Seitenwand
 Clip pour paroi
 Clip voor zijwand
 Bracket for side
 cladding

4 Spreizniet
 Rivet à expansion
 Tiknagel
 Body-bound rivet



Stützrahmen
Echelle
Stellingkader
Frame

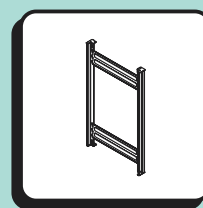

**Stützrahmen liegend
 montieren**

**Monter les composants
 de l'échelle en les
 posant par terre**

**Onderdelen van stelling-
 kader op de vloer
 monteren**

**Place frame components
 on the floor for assembly**

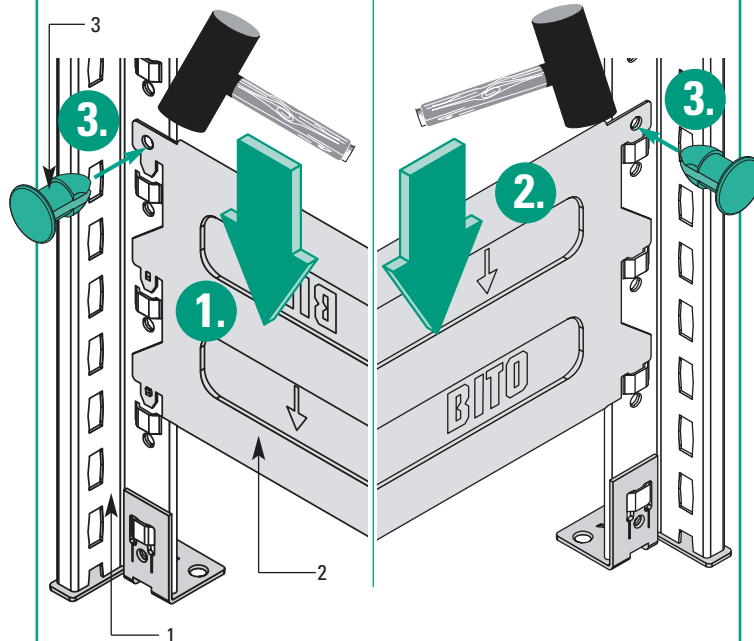
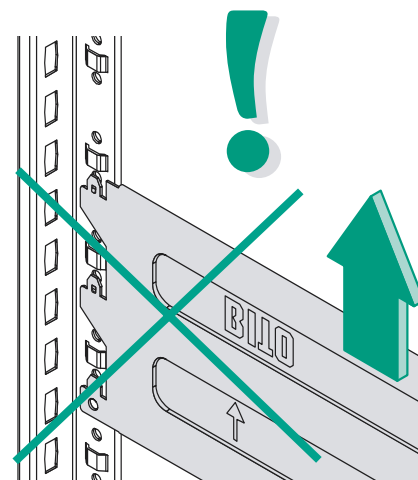

Jeder Stützenverbinder wird nach dem Einsetzen mit 2 Nieten gesichert.

Chaque raidisseur pour montants doit être arrêté par 2 rivets.

Iedere dwarsverbinding tussen twee staanders wordt door 2 nieten beveiligd.

Every upright connector has to be fixed by 2 rivets.

1 Stütze
 Montant
 Staander
 Upright

2 Stützenverbinder
 Raidisseur pour
 montants
 Dwarsverbinding
 Upright connector

3 Niet (Kunststoff)
 Rivet en matière
 plastique
 Kunststoffniet
 Plastic rivet

Ø5 x 4 mm

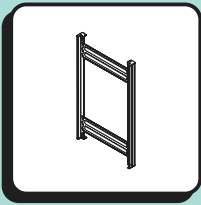

Stützrahmen
Echelle
Stellingkader
Frame

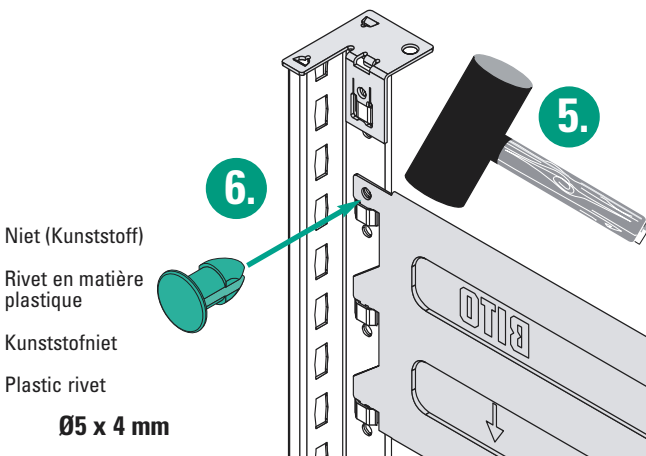
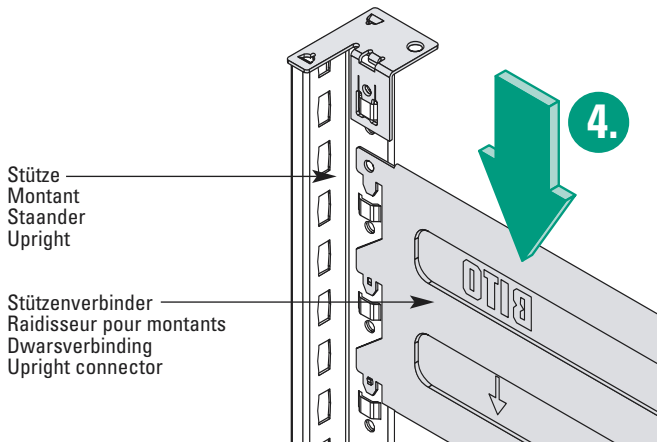

! Jeder Stützenverbinder wird nach dem Einsetzen mit 2 Nieten gesichert.
Chaque raidisseur pour montants doit être arrêté par 2 rivets.
Iedere dwarsverbinding tussen twee staanders wordt door 2 nieten beveiligd.
Every upright connector has to be fixed by 2 rivets.

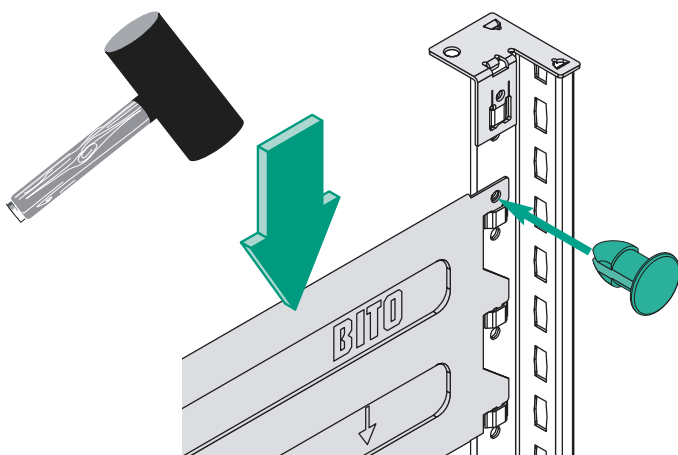

Feldansicht
Structure de base
Onderstel
Stand

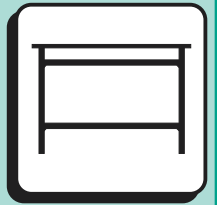

1 Feld
1 travée
1 vak
1 bay

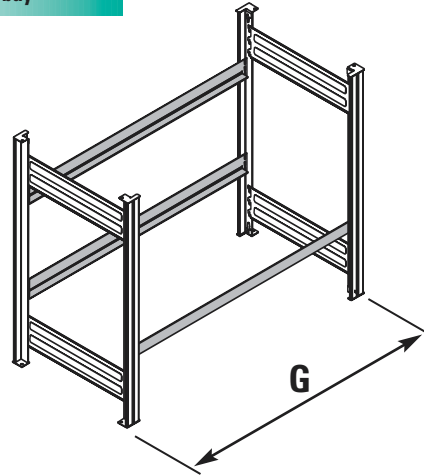

A=
Anbaufeld
Travée d'extension
Aanbouwvak
Extension bay

2 Felder
2 travées
2 vakken
2 bays

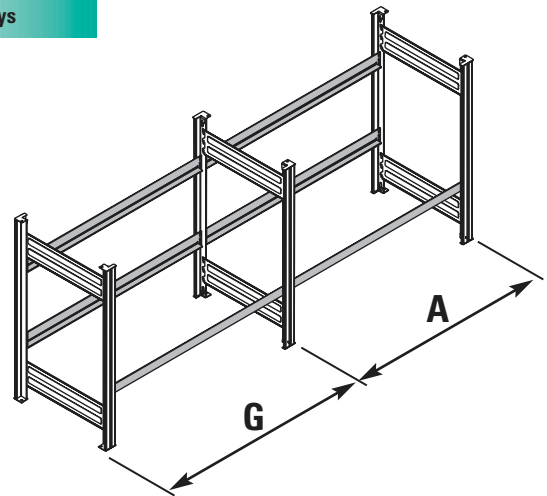

3 Felder
3 travées
3 vakken
3 bays

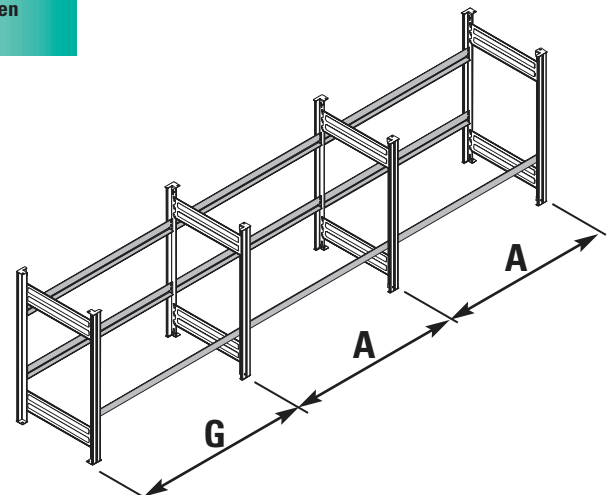

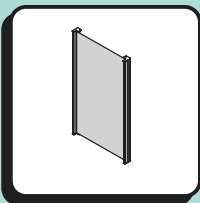

Rückwand-Vollblech
Fond tôlé
Volle rugwand
Closed back cladding

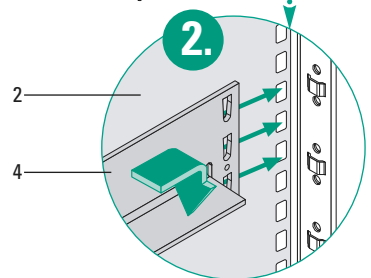
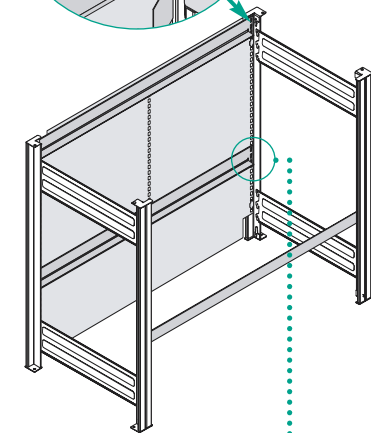
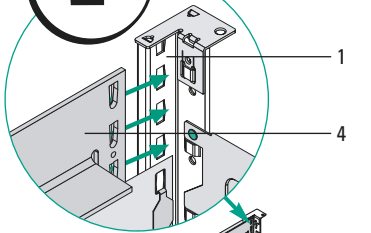
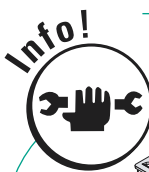
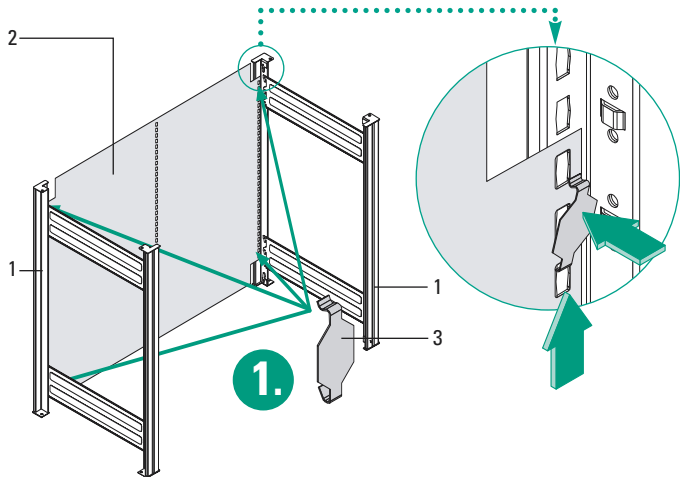

1 Stützrahmen
 Echelle
 Stellingkader
 Frame

2 Rückwand-Vollblech
 Fond tôlé
 Volle rugwand
 Closed back cladding

3 Federklammer
 Agrafe en acier
 Veerstaal-klem
 Clip

4 Traverse
 Longeron
 Ligger
 Beam

5 Sicherungsstift
 Goupille de sécurité
 Borgpen
 Safety pin

6 Halteklammer oben
 Clip de fixation pour fond
 tôlé/longeron (en haut)
 Bevestigingsclip voor volle
 rugwand/ligger (boven)
 Bracket for closed back
 cladding/beam (top)

7 Halteklammer
 Vollblechrückwand
 Clip de fixation pour fond
 tôlé/tablette
 Bevestigingsclip voor volle
 rugwand/legbord
 Bracket for closed back
 cladding/shelf

8 Bolzen Halteklammern
 Boulon pour clip de fixation
 Bout voor bevestigingsclip
 Bolt for bracket

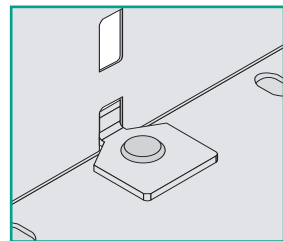
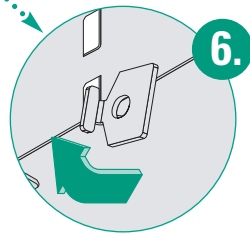
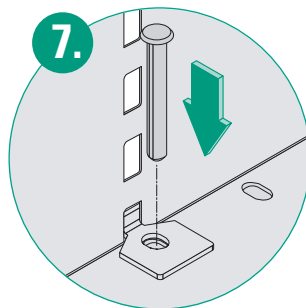
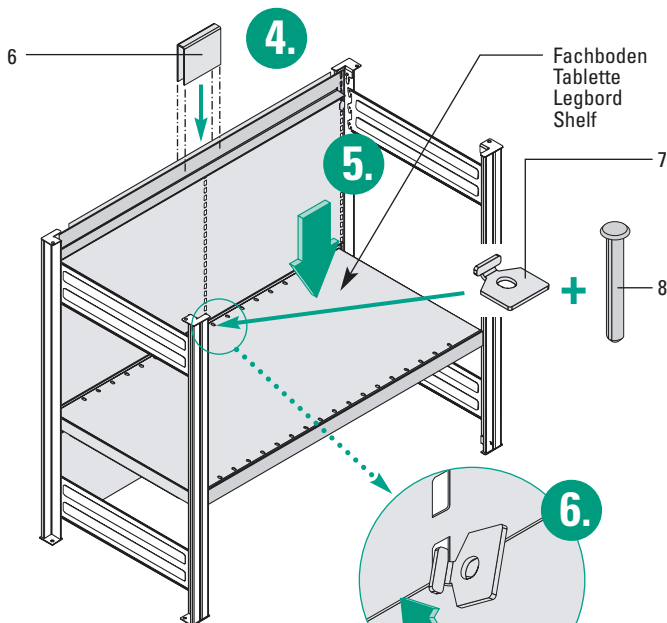

Traverse
Longeron
Ligger
Beam

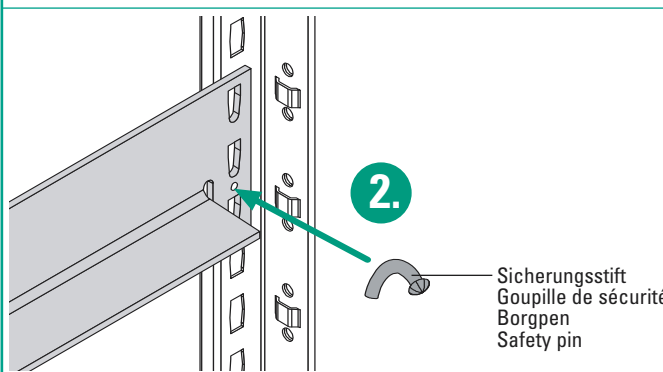
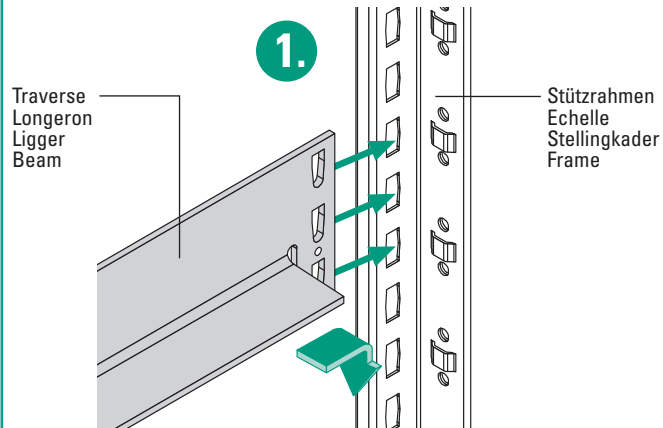
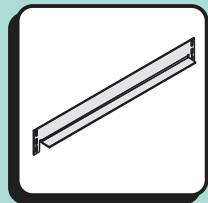

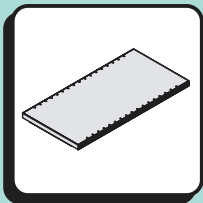

Fachboden
Tablette
Legbord
Shelf

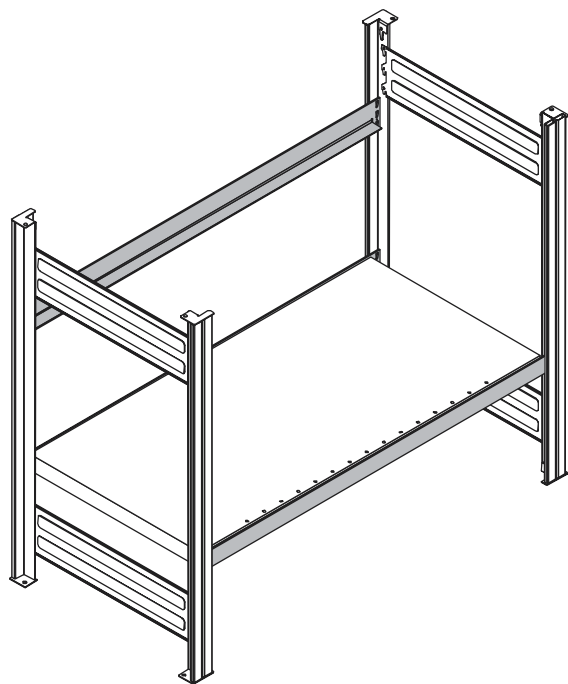
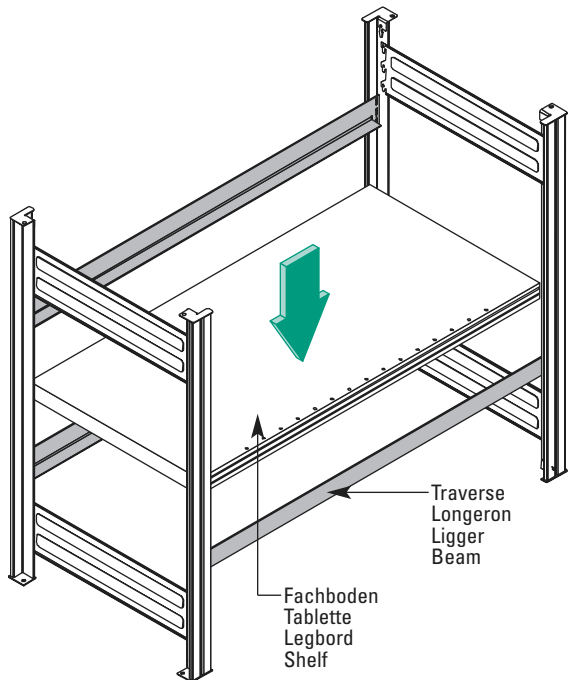

Arbeitsplatte
Plateau
Werkblad
Top

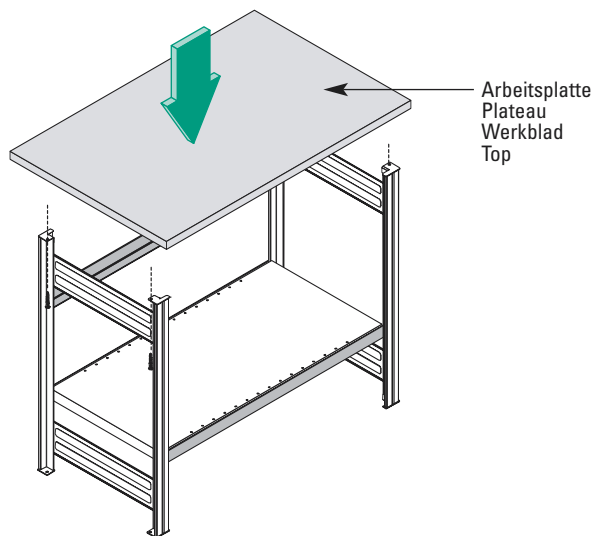
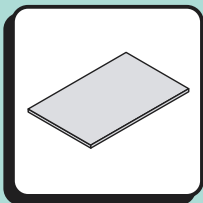

! Arbeitsplatte vorbohren
Perçage préalable du plateau pour vis
Werkblad voorboren voor de schroeven
Prepare workbench top with drill holes for bolts

→ siehe Seite
se référer à page
zie pagina
refer to page

13

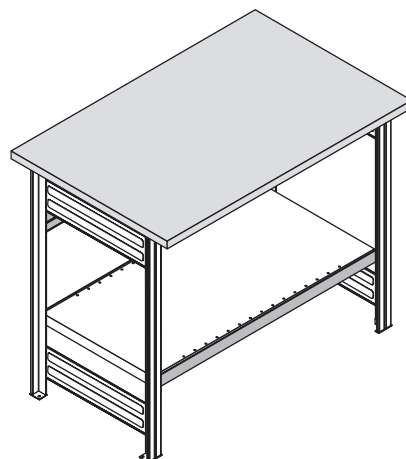
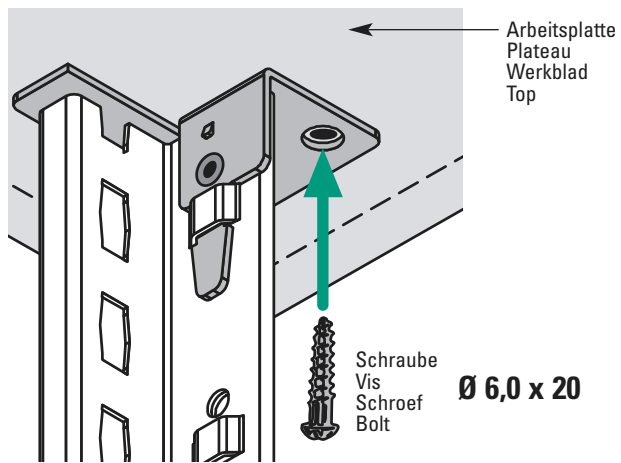

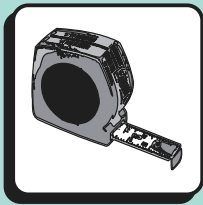

**Abmessungen
Dimensions
Afmetingen
Dimensions**



Montage mit Schublade siehe Seite
Pour montage avec tiroir se référer à page
Voor montage met schuiflade zie pagina
For assembly with drawer refer to page

15

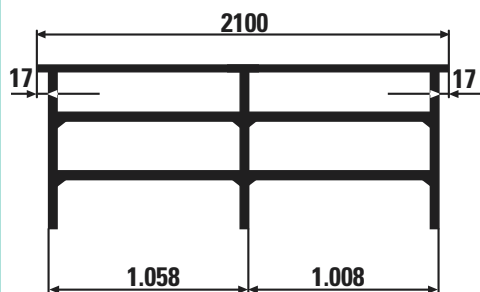
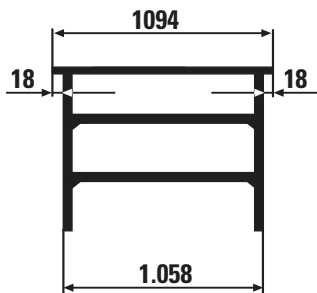

Stoß
Bords des deux éléments à accoupler
Met elkaar te verbinden randen
Edges to be joined

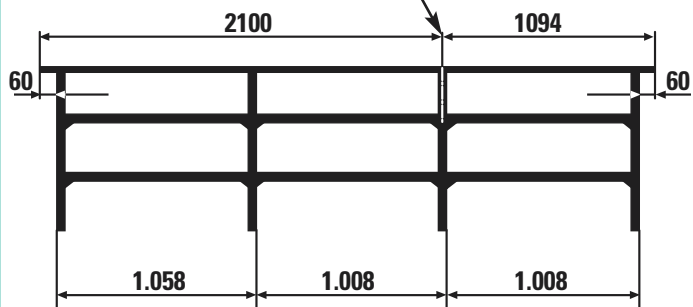

Verbindungsplatte
Plaque d'accouplement
Verbindingsplaat
Connector plate

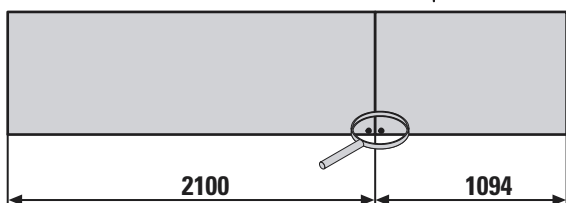
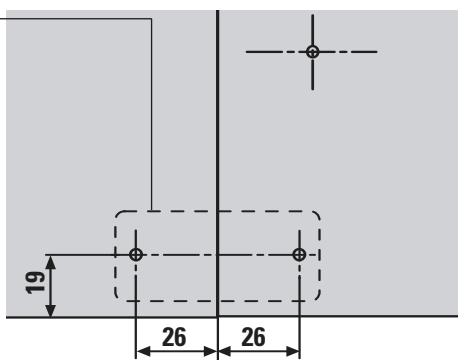

**Vorbohren
Perçage préalable avec
un diamètre inférieur
Voorboren
Pre-drilling with a smaller diameter**

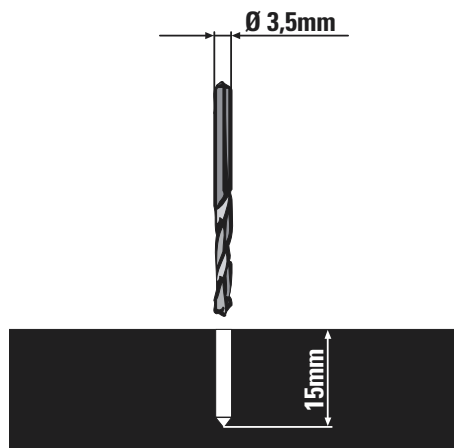
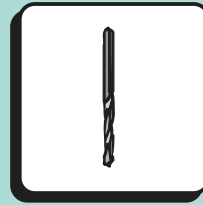

**Verbindungsplatte
Plaque d'accouplement
Verbindingsplaat
Connector plate**

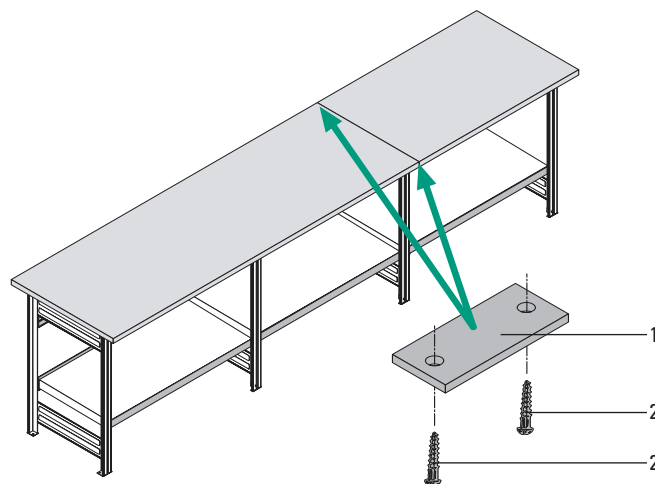
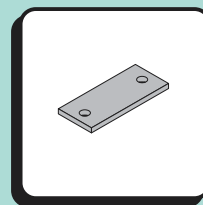

1 Verbindungsplatte
Plaque d'accouplement
Verbindingsplaat
Connector plate

2 Schraube
Vis
Schroef
Bolt

Ø 6,0 x 20

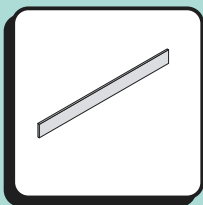

Bordbrett
Rebord
Boordplank
Back board



Schraube
 Vis
 Schroef
 Bolt

Ø 6,0 x 20

Arbeitsplatte
 Plateau
 Werkblad
 Top

Bordbrett
 Rebord
 Boordplank
 Back board

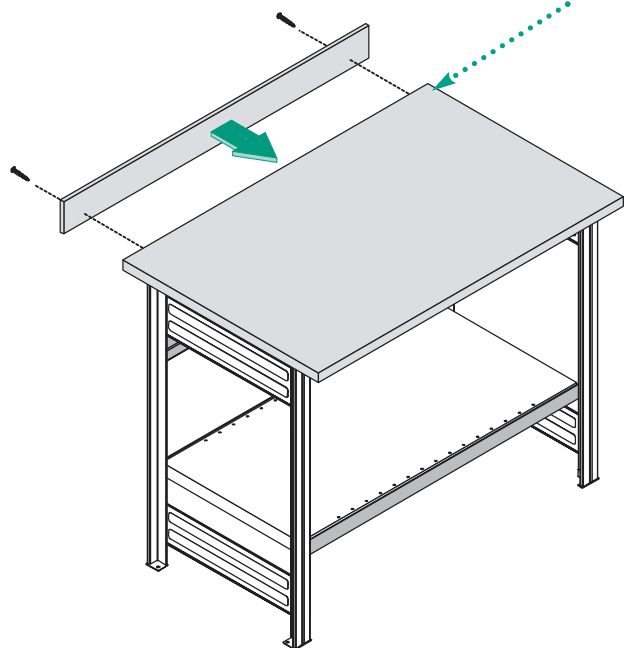
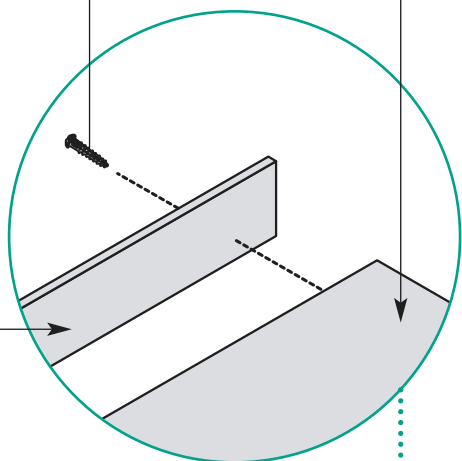

Schublade
Tiroir
Schuiflade
Drawer

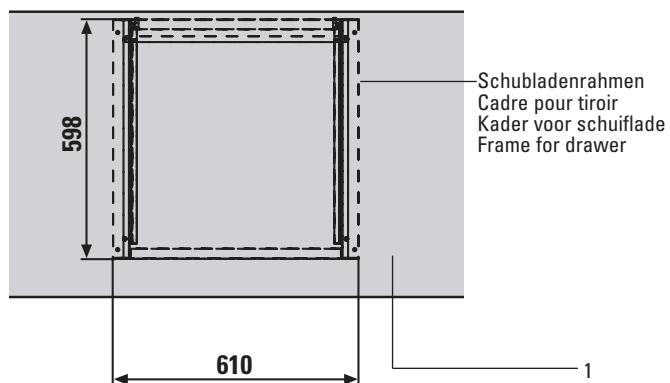
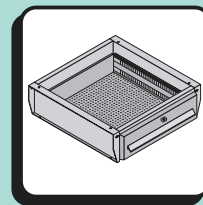

Schubladenrahmen
 Cadre pour tiroir
 Kader voor schuiflade
 Frame for drawer

1.

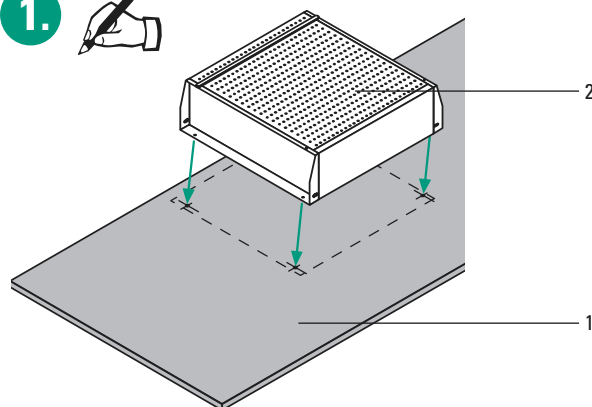

1 Arbeitsplatte
 Plateau
 Werkblad
 Top

2 Rahmen mit Schublade
 Tiroir avec cadre
 Schuiflade met kader
 Drawer complete with
 frame

3 Schraube
 Vis
 Schroef
 Bolt

Ø 6,0 x 20

2.

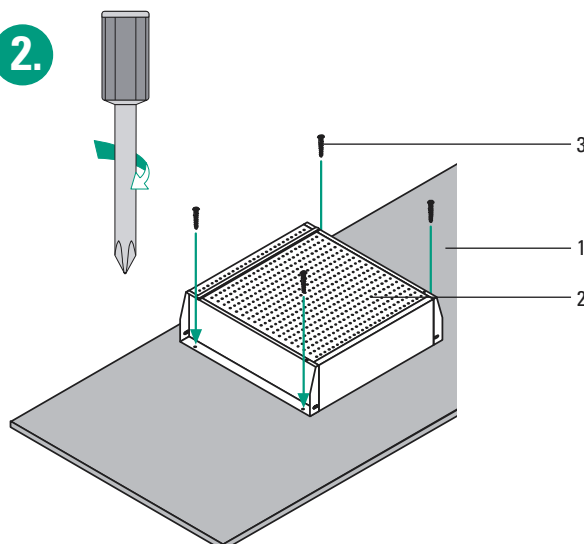

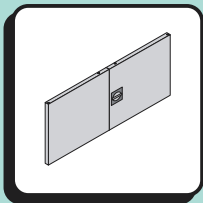

Flügeltüren
Portes battantes
Vleugeldeuren
Hinged doors

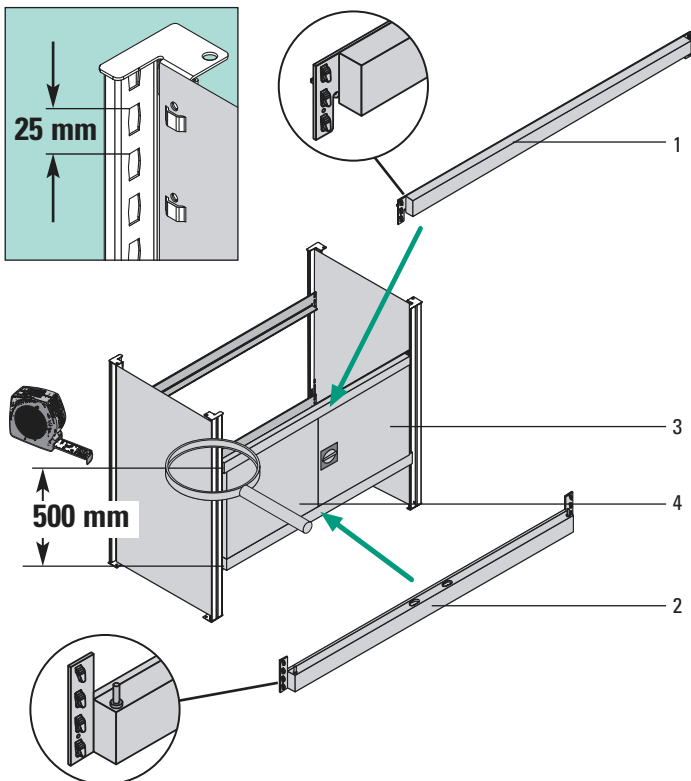

1 Türlager oben
 Palier au longeron
 supérieur
 Deurstijl boven
 Door bearing at upper
 beam

2 Türlager unten
 Palier au longeron au
 sol
 Deurstijl aan
 vloerligger
 Door bearing at
 bottom beam

3 Türblatt rechts
 Battant droit
 Vleugel rechts
 Right-hand door leaf

4 Türblatt links
 Battant gauche
 Vleugel links
 Left-hand door leaf

5 Sicherungsstift
 Goupille de sécurité
 Borgpen
 Safety pin

6 Türzapfen
 Fusée d'essieu pour
 palier supérieur
 Insteekhaak deurstijl
 boven
 Spigot for upper door
 bearing

7 Fachboden
 Tablette
 Legbord
 Shelf

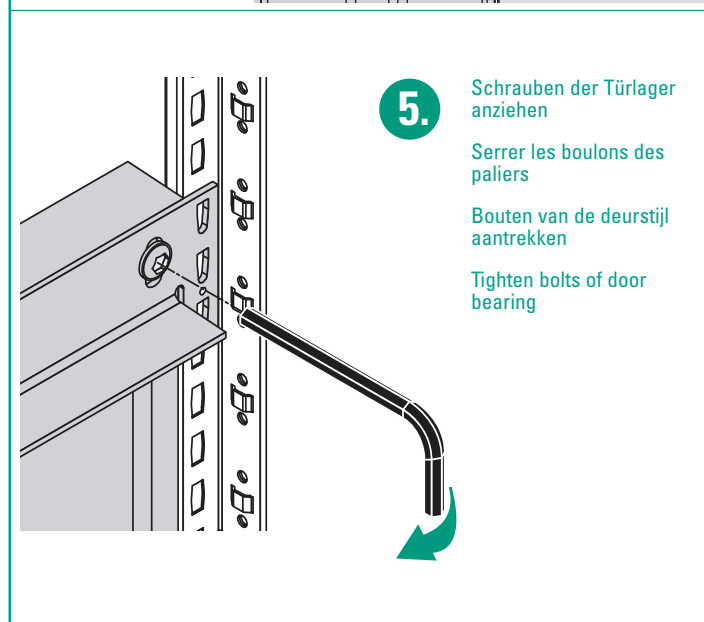
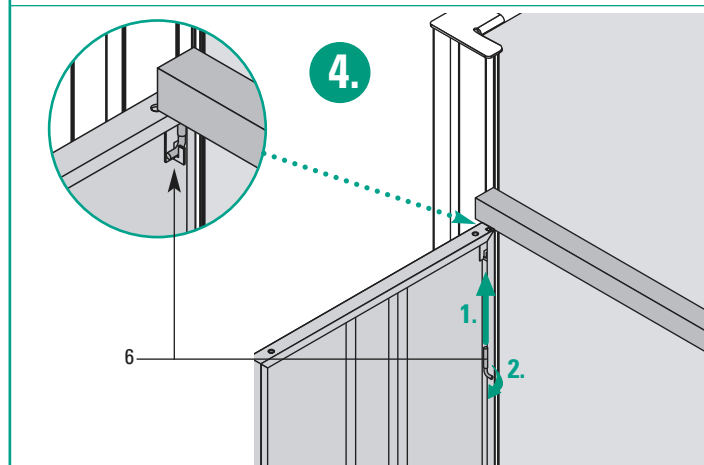
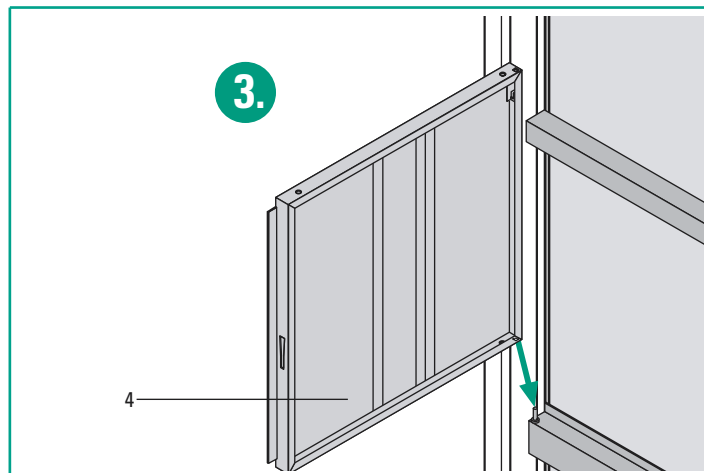
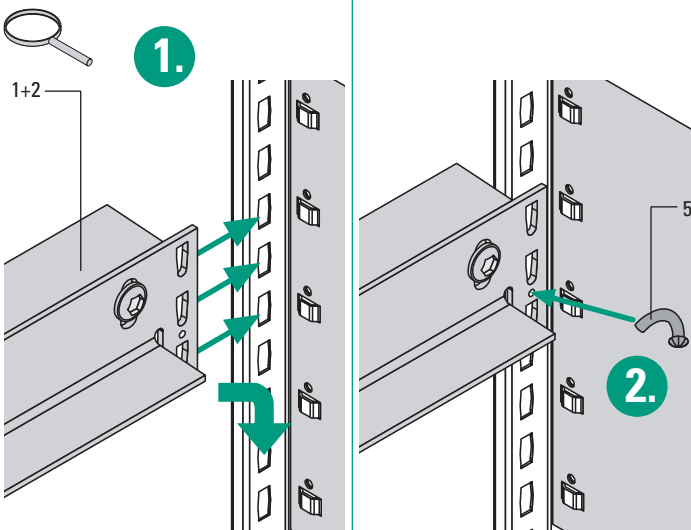

5. Schrauben der Türlager
 anziehen
 Serrer les boulons des
 paliers
 Bouten van de deurstijl
 aantrekken
 Tighten bolts of door
 bearing

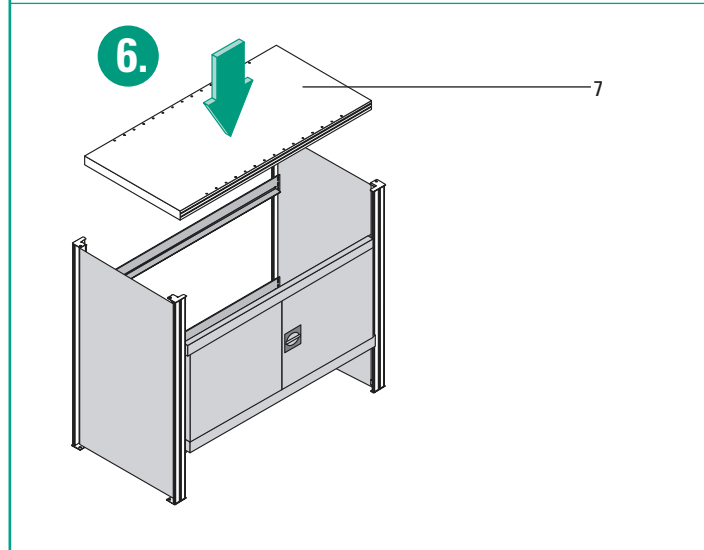

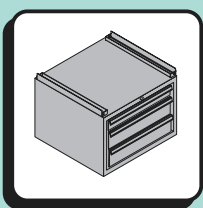

Schubladenblock
Bloc tiroir
Ladenblok
Drawer unit

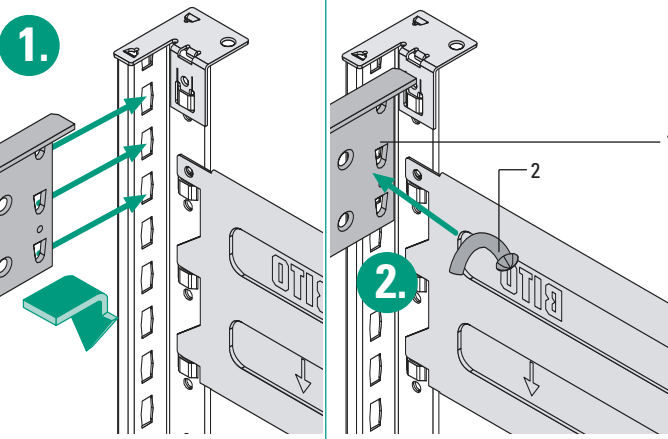
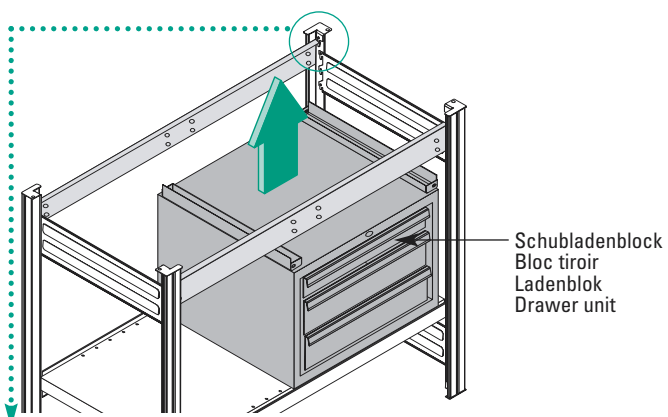

1 Traverse
 Schubladenblock
 Longeron pour fixation
 bloc tiroir
 Ligger voor het vast-
 schroeven van laden-
 blok
 Beam for mounting
 drawer unit

2 Sicherungsstift
 Goupille de sécurité
 Borgpen
 Safety pin

3 Schraube
 Vis
 Schroef
 Bolt

4 Mutter
 Ecrou
 Moer
 Nut

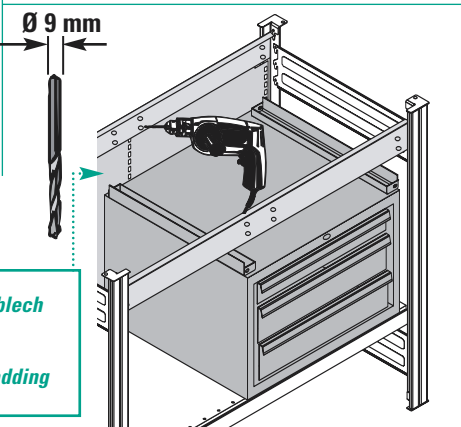
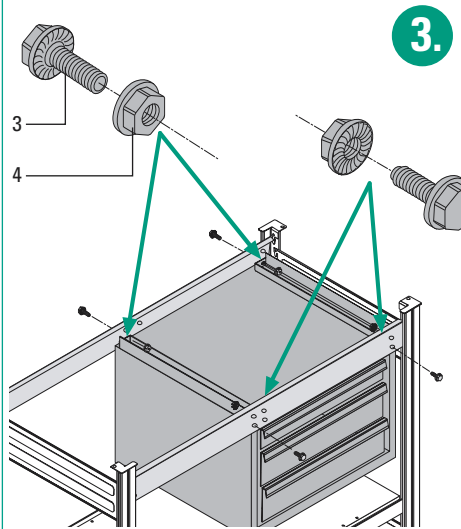

! Rückwand-Vollblech
 Fond tôlé
 Volle rugwand
 Closed back cladding



Dübel
Cheville
Vloeranker
Floor anchor

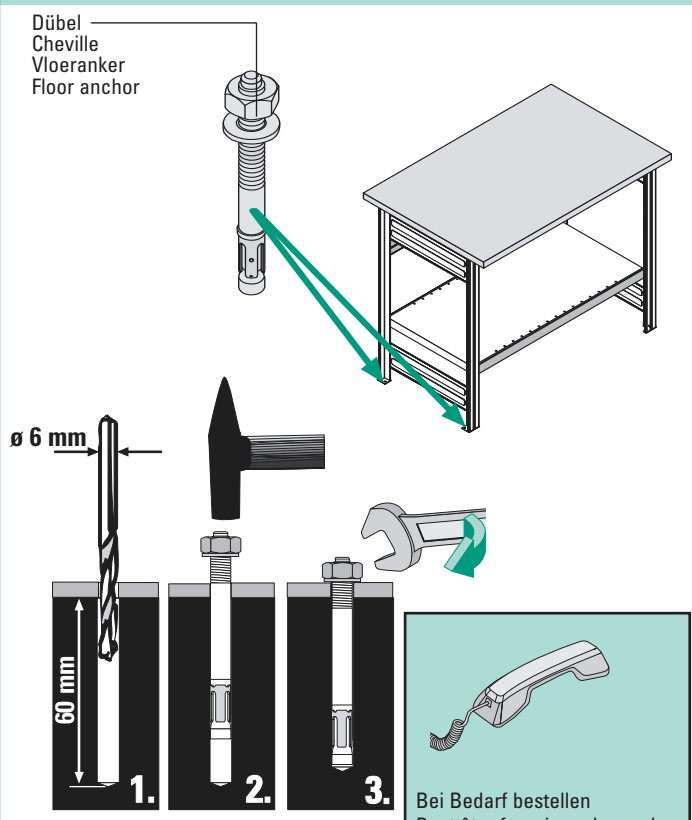
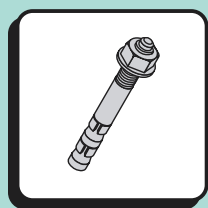

Bei Bedarf bestellen
 Peut être fourni sur demande
 Levering op aanvraag mogelijk
 Can be supplied upon request



Unterlegblech
Cale
Nivelleerplaat
Levelling plate

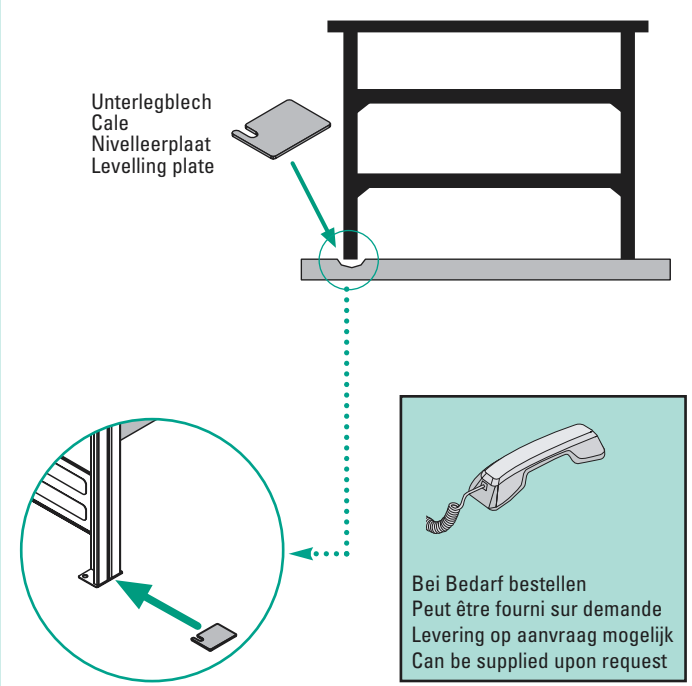
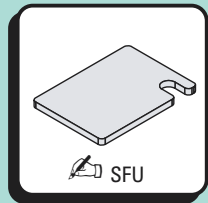

Bei Bedarf bestellen
 Peut être fourni sur demande
 Levering op aanvraag mogelijk
 Can be supplied upon request